

CAPRI-ELBA PEDI SPA

ORIGINAL INSTRUCTIONS - REV. 2 / 2023



CAPRI PEDI SPA



ELBA PEDI SPA



INSTRUCTION FOR USE	pag. 3
ISTRUZIONI PER L'USO	pag. 17
NOTICE D'UTILISATION	pag. 31
BEDIENUNGSANLEITUNG	seite. 45

EN**Congratulation for having chosen an equipment LEMI produced by Brusaferrri & C.**

This equipment has been designed and built using state of the art technologies and processes to guarantee the best reliability in the time and ensure maximum safety.

This equipment is suitable for professional pedicure.

For a correct and safe operation of the equipment is essential to carefully read and observe what is indicated in this manual. All documentation accompanying the equipment – and in particular this manual – must be carefully preserved for future reference.

IT**Complimenti per aver scelto un'attrezzatura LEMI prodotta da Brusaferrri & C.**

Questa apparecchiatura è stata progettata e costruita utilizzando tecnologie e procedimenti allo stato dell'arte per garantirne la migliore affidabilità nel tempo ed assicurarne la massima sicurezza.

Questa apparecchiatura è adatta per trattamenti professionali di pedicure.

Per un corretto e sicuro funzionamento dell'apparecchiatura è indispensabile leggere attentamente ed osservare quanto indicato nel presente manuale. Tutta la documentazione di corredo dell'apparecchiatura - ed in particolar modo il presente manuale - deve essere accuratamente conservata per riferimenti futuri.

FR**Félicitations d'avoir choisi un équipement fabriqué par Brusaferrri & C.**

Cet équipement a été conçu et construit en utilisant des technologies et des procédés de qualité élevée afin de garantir la plus grande fiabilité à long terme et d'assurer la plus grande sécurité.

Cet équipement a été conçu pour les traitements professionnels de pédicure.

Pour un bon fonctionnement de l'équipement il est indispensable de lire attentivement et de respecter les indications fournies par la présente notice. Toute la documentation fournie avec l'équipement doit être soigneusement conservée pour utilisation ultérieure.

DE**Herzlichen Glückwunsch für eine Ausrüstung LEMI erzeugten von Brusaferrri & C. gewählt zu haben.**

Diese Liege wurde verwendend die modernster Technologien und Prozesse entwickelt und gebaut, um die beste Zuverlässigkeit in der Zeit und die maximale Sicherheit zu versichern.

Dieses Gerät ist für die professionelle Pediküre geeignet. Für einen korrekten und sicheren Betrieb der Liege ist es wichtig, was in diesem Handbuch angegeben sorgfältig zu lesen und beachten,. Die ganze Unterlagen geliefert mit der Liege – und insbesondere dieses Handbuch – es muss sorgfältig für die Zukunft erhalten bleiben.

EN- INSTRUCTION FOR USE

1. GENERAL REGULATION _____ pag. 4

2. INSTALLATION _____ pag. 5

3. OPERATING PROCEDURES _____ pag. 9

4. INSTALLATION DIAGRAM _____ pag. 13

5. CLEANING _____ pag. 14

6. MAINTENANCE _____ pag. 16

DIMENSIONS _____ pag. 17

1. GENERAL REGULATION

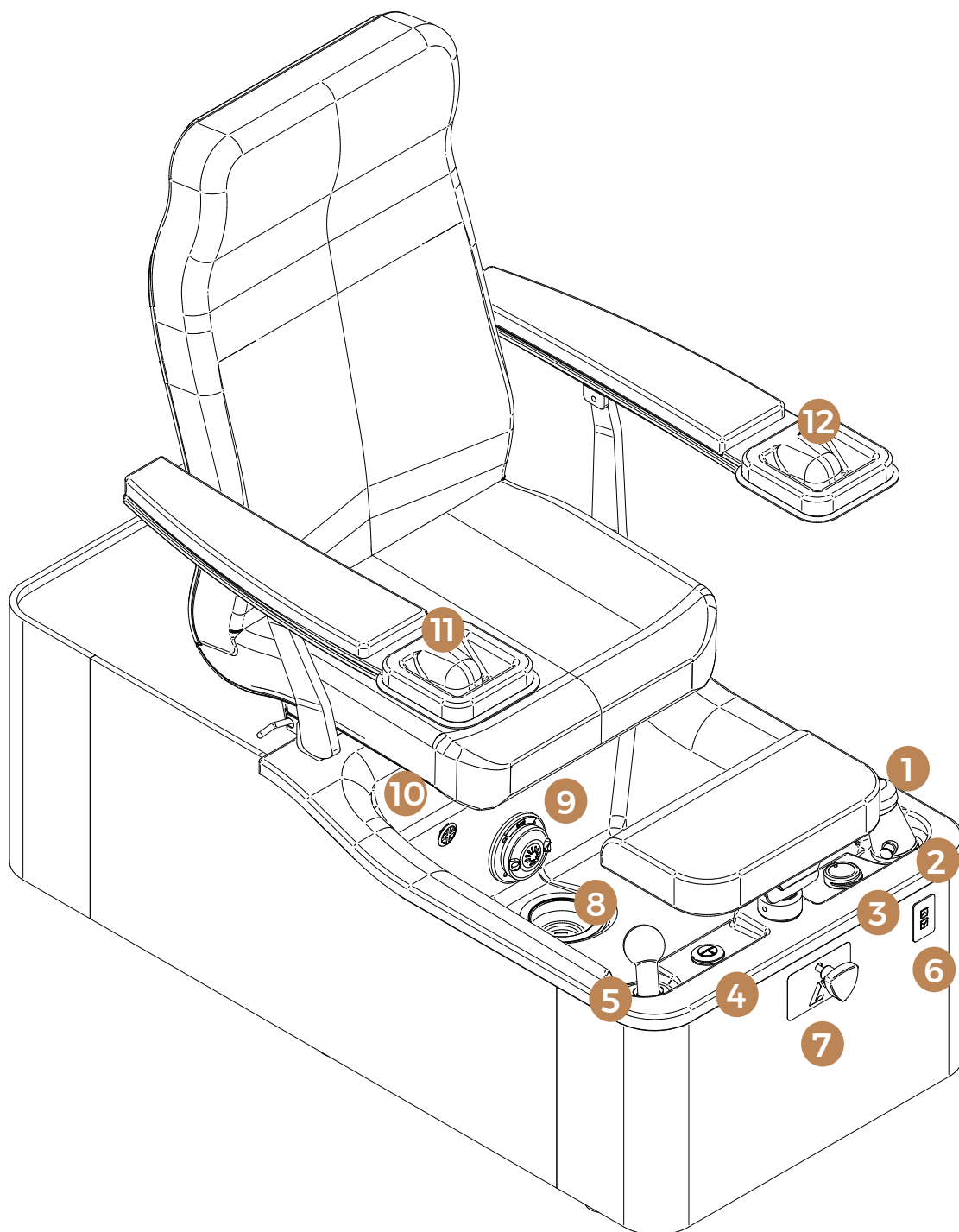

DESCRIPTION OF PRODUCTS

- | | |
|---------------------------------------|---|
| 1. Water temperature mixer (tap) | 7. Handgrip for vertical adjustment of the footrest |
| 2. Diverter for manual hand shower | 8. Drain |
| 3. Drain handgrip | 9. Hydromassage Magna jet |
| 4. Start button | 10. Full drain |
| 5. Hand shower | 11. Frame of the handrest tray |
| 6. Adjustment button of seat position | 12. Handrest tray |

2. INSTALLATION

2.1. Positioning

Important: Important: CAPRI / ELBA PediSpa were designed to be installed as a fixed unit and they have to be positioned in an appropriate structure and on a stable floor.

All equipment containing water at a working level, weighs about 141 Kg.

It is recommended to consult a technician before positioning the equipment in a suitable cabin.



ATTENTION! The pedicure station is equipped with 4 perimeter adjustable feet. It is important that the 4 feet are regulated to level each imperfection of the floor.



ATTENTION! To position in the cabin or move of your pedicure station, place your hands under the wooden basin cover taking only the metallic frame base.



NEVER LIFT CAPRI / ELBA PEDISPA BY TAKING THE WOODEN COVER.

2.2. Disassembly of the wooden basin cover



ATTENTION! Capri / Elba Pedispa will be delivered with the chair disassembled from the basin shown in the figure below.



2.3. Base disassembly



STEP 1: Remove the upper covering plate.



STEP 2: Unscrew the 4 screws using the suitable key to remove the rear wooden cover



STEP 3: Remove the rear wooden cover



STEP 4: Remove the left lateral wooden cover.

2.4. Hydraulic Connections



ATTENTION! All hydraulic connections must be realized by a licensed plumber according to the local and national plumbing requirements.



ATTENTION! Before connecting hot and cold water pipes to the water supply system, let the water flow from the water supply to make sure that all wastes come out from the inner piping.

CONNECTIONS:

- Hot and cold water pipes connections must be realized with 1/2" or similar.
- **HOT WATER (RED)** 1/2" female
- **COLD WATER** 1/2" female



IMPORTANT: Drain connections are \varnothing 40 mm PVC flexible pipe.

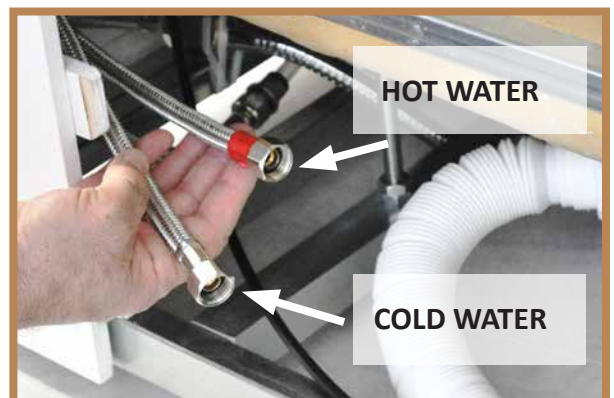

N.B: For a regular flow of water we suggest the Ø40 mm floor drain as low as possible (floor level). Connections must be realized according to the requirements of the existing local and National rules.

We recommend to use resistant tiles on the surrounding floor. In addition to the Capri PediSpa drain, we recommend to slope the floor towards a second drain in case of water outflow.

These precautions will assure both the client and the operator a safe environment.



2.5. Electrical connections

Insert the plug into a suitable electrical socket to operate the appliance.



ATTENTION: if there is incompatibility between the socket and the plug of the equipment, replace the socket with a suitable type by professionally qualified personnel. Pull the plug from the power outlet grasping the plug, not the cable.

2.6. Seat installation



STEP 1: Unscrew the screw on the pin of the seat.



STEP 2: To fix the armchair on the basin, take the metal part that connects the arm to the back and place the pin inside the hole on the metal frame of the basin.



IMPORTANT: Make sure that the brass ring on the pin remains fixed when you place the seat.



STEP 3: Screw to fix the seat.

2.7. Installation of the perimeter wooden covers



STEP 1: Reassemble the left and right wooden cover sliding as shown in the picture.



STEP 2: Reassemble the rear wooden cover in the appropriate guides and pressing on the sides to fix it.



STEP 3: Fix the rear wooden cover screwing the 4 screws (2 upper and 2 lower) using the appropriate key.



STEP 4: Close the upper covering plate.

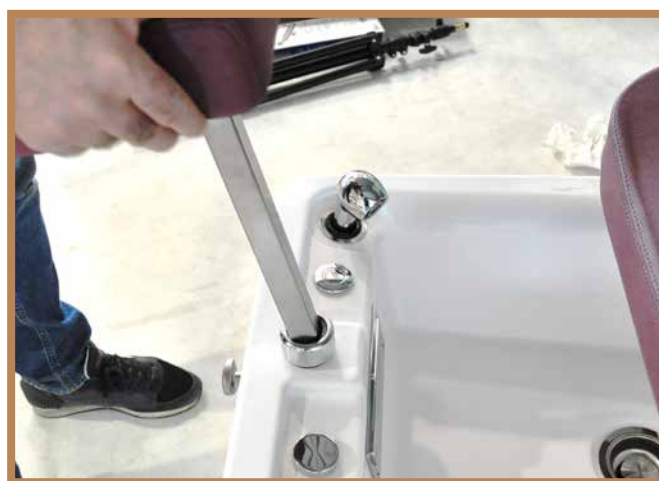

STEP 5: Install the foot rest in the appropriate hole as shown in the picture. For its adjustment, see "3. Operating procedures".

3. OPERATING PROCEDURES

3.1. Filling the basin:

Before filling your Capri Pedi Spa/Elba Pedi Spa with water, make sure the basin is clean and sterilized and that any debris is inside the basin to avoid the risk of scratching the acrylic surface.

Open the water tap and adjust the water temperature by turning it on the right for hot water, and left for cold water.



**DO NOT ACTIVATE THE HYDROMASSAGE PUMP WITHOUT WATER.
THE WATER LEVEL MUST ALWAYS COVER THE HYDROMASSAGE MAGNA JET.**

3.2. Use and maintenance of the equipment

AUTOMATIC FILLING OF THE BASIN AND HYDROMASSAGE ACTIVATION (ONLY FOR CAPRI PEDI SPA)

Press the **AUTO FILL** button to automatically fill the basin (sensor up to the set level).

When water reaches the level, the water outlet stops and the jet of air (hydro massage) activate automatically.

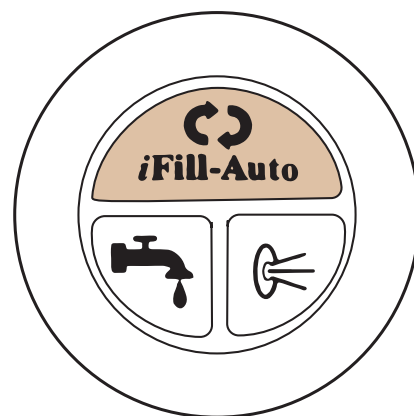

MANUAL FILLING OF THE BASIN (ONLY FOR CAPRI PEDI SPA)

Press the **TAP** button for manual filling. To stop the water outlet, press again the tap button.



**THE WATER LEVEL MUST ALWAYS COVER
THE HYDROMASSAGE MAGNA JET.**

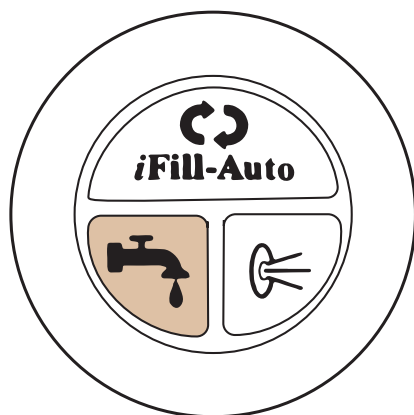

HYDROMASSAGE

To activate the hydromassage press the button with the **PUMP** icon, once the water has reached the magna jet level.

HYDROMASSAGE (FOR ELBA PEDI SPA)

To activate the hydromassage on **Elba Pedi Spa**, press the whole button.

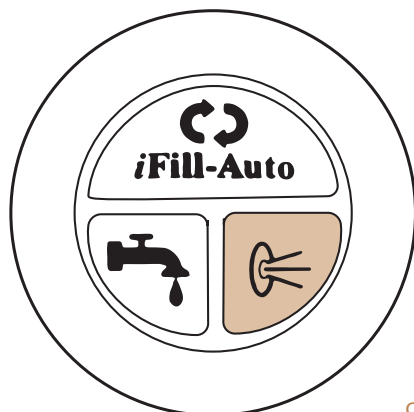



ATTENTION!

THE WATER LEVEL MUST ALWAYS COVER THE HYDROMASSAGE MAGNA JET (A).

In fact, after 30 SECONDS that the pump runs dry (B) or with a partial level of water (C), the impeller risks to over heat and break, becoming unusable. Any intervention carried out on the machine as a result of incorrect use of these instructions will not be considered under warranty.



A. The water level must ALWAYS COVER THE HYDROMASSAGE MAGNA JET



B. Condition of the impeller ruined for ABSENCE OF WATER



C. Condition of the impeller ruined for PARTIAL FILLING

3.3. Control unit RESET procedure (ONLY for CAPRI PEDI SPA)

In case your Capri Pedi Spa has operating problems, in particular with the system iFill-Auto auto fill, we suggest you proceed with the following reset procedure:

- 1) Switch off the power to the machine for a few seconds, wait a few seconds and then connect the Capri Pedi Spa to the power supply again. **Press and hold the iFill-Auto auto fill button** until it emits a prolonged sound and as soon as the pressure is released the leds will start to flash.

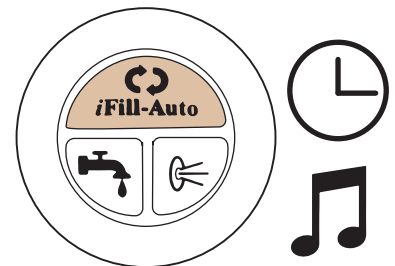

- 2) After hearing the sound, **press the hydromassage operation button**

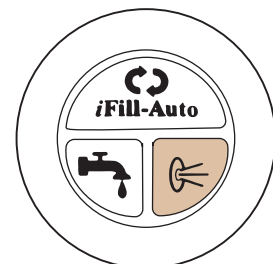

3.4. Hydromassage magna jet cleaning

1. Remove it from the basin
2. Rotate the 2 plastic covers to open
3. Separate the 2 plastic parts
4. Remove the internal impeller
5. Clean it:
 - 5.1. Place the plastic covers and the impeller in a bath with 20 cl Saniguest detergent
 - 5.2. Cover with clean water
 - 5.3. Soak for about 2 hours
 - 5.4. Dry with a soft clean cloth, do not use abrasive sponge
6. Reassemble the parts
7. Place the jet on the basin



3.5. Position the hydromassage magna jet

The magna jet must be positioned with the holes horizontally. Thanks to the magnet, the component will fix to the basin.



3.6. Use of hand shower

To use the hand shower, pull the diverter placed on the tap and rotate it to lock. In this way, water will flow out from the hand shower. Place the hand shower in the appropriate hole on the left of the basin when you do not use it.



3.7. Drain

Rotate left/right to close or open the drain



3.8. Footrest adjustment

To adjust the footrest height, unscrew anticlockwise the front knob and move the upholstered part up or down with the other hand. Rotate clockwise to fix the position.



To slide the upholstered cushion forwards or backwards, unscrew the black knob and screw to fix the position



3.9. Seat adjustment and inclination

The seat is electrically adjustable forwards or backwards.

To adjust the seat, press the buttons in the front side of the basin.



To adjust the recliner of the seat, pull the lever on the right side of the chair and move the back of the seat.

Release the lever to fix.

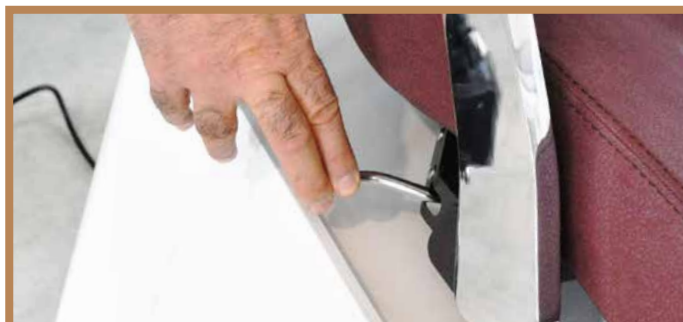

3.10. Seat rotation adjustment

The chair can rotate 180° from side to side to facilitate access to the customer. Move the chair left or right.



ATTENTION! The client should never be allowed to enter or exit the chair except in “rotated” position.

3.11. Positioning of manicure trays

Place the metal frame on each armrest.
Place the tray on the frame.



4. INSTALLATION DIAGRAM

4.1. Electricity / water connection

POWER SUPPLY CONNECTION:

Voltage 220V 2 phase + heart

Socket 10A min

WATER FLOW RATE:

8 liters / minute

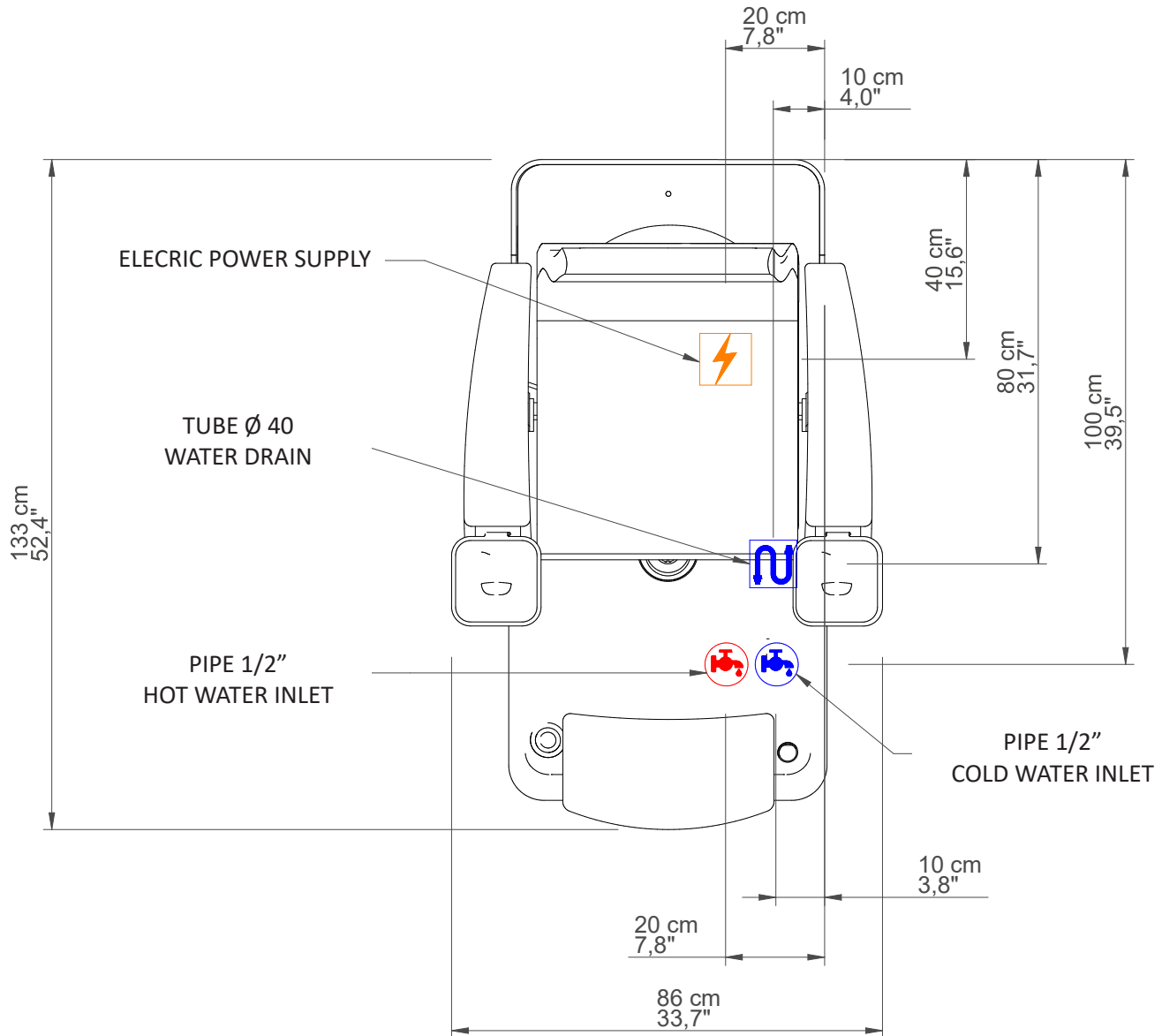

ATTENTION! for wall drain, the drain pump (optional) must be added



ATTENTION!

The Wall mounted drain pump kit is mounted inside the case of the PediSpa and is connected externally via a **LIGURIA type rubber hose Ø 22mm, 3m in length**

5. CLEANING

FIBERGLASS BASIN CLEANING



It is forbidden to use the following products which could seriously damage the plastic covering, provoking cracks and the subsequent breaking:

- Degreasing solvent-based agents: e.g. ACETONE, DENATURED ETHYL ALCOHOL, TRICHLOROETHYLENE, FUEL, TURPENTINE...
- Watered-down acids (HYDROCHLORIDRIC ACID, NITRIC ACID) or products containing watered-down acids
- Watered-down bases (CAUSTIC SODA, SODIUM HYPOCHLORITE, AMMONIA, BLEACH) or products containing weak bases
- Fluorinated hydrocarbons (e.g. LEAKS FROM REFRIGERANT GAS)
- Food-grade oils (e.g. OLIVE OIL, SEEDS OIL)
- Lubricating mineral-based oils



To CLEAN the basin we recommend:

- Soap water (neutral soap)
- Soft sponge

Always rinse with clean water and dry with a soft, not abrasive cloth.

CHAIR CLEANING

We suggest to cover the chair with a towel or disposal sheet before the client sits.



Pay particular attention to the jeans that can stain the covering without any possibility of being removed.

Clean the chair before each use, paying particular attention to remove all traces of physiological fluids of the previous patient.



To clean the chair use a cloth and lukewarm water (if necessary diluted neutral detergent). If necessary, use a non-aggressive disinfectant, then wipe off with a clean dry cloth.

Do not use products such as alcohol, acetone, bleach, paint thinner, gasoline.

MAINTENANCE

1) AFTER each single treatment/client, BEFORE starting a new treatment:

Empty the basin, SPRAY the basin with contact disinfectant SANIGUEST and clean it with a soft sponge or cloth. Rinse the basin with the hand shower.

2) REGULARLY (once a week or every 2 weeks, according to the water hardness):

SPRAY the basin with GO KAL anti-scale, carefully avoiding contact with eyes and skin. Clean it with soft sponge or cloth. Let water flow from jets copiously for some seconds in order to remove any strong deposit. Rinse with hand shower.



IMPORTANT! Do not use any cream or powder cleanser, pure disinfectant or any scratching sponge or cloth!
DO NOT USE BLEACHING SOLUTION OR ANY OTHER CORROSIVE PRODUCTS TO CLEAN THE CHAIR

N.B. If you need to order our SANIGUEST and GO KAL disinfectant, please contact us by phone +39/0374/36.30.69 or email orders@lemigroup.it

The strict observance of these easy cleaning and maintenance instructions will keep your basin clean, white and bright for long time.

DIMENSIONS

Dimensions in cm and inches

CAPRI PEDI SPA

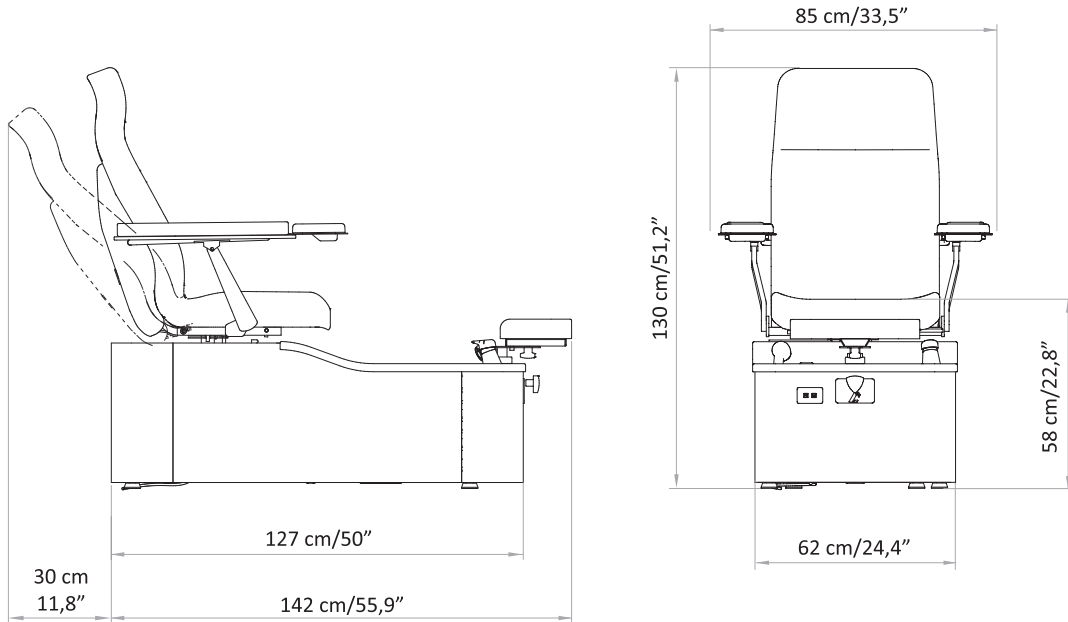

ELBA PEDI SPA

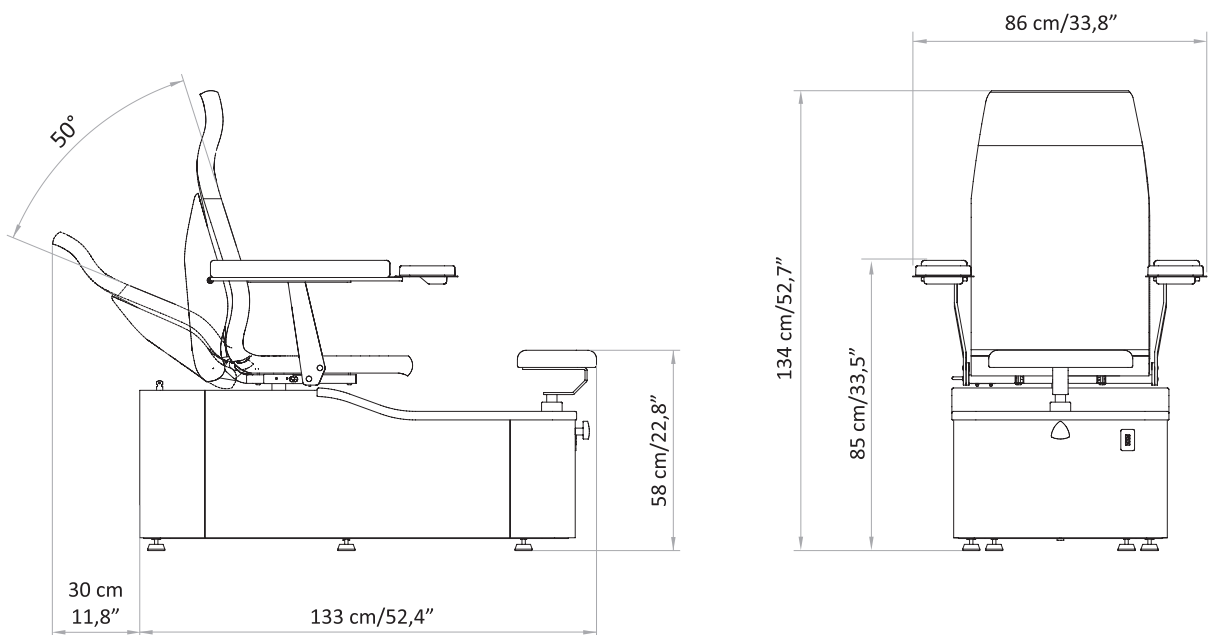

IT- ISTRUZIONI PER L'USO

1. REGOLAZIONE GENERALE pag. 18

2. INSTALLAZIONE pag. 19

3. PROCEDURE OPERATIVE DI UTILIZZO pag. 23

4. SCHEMA DI INSTALLAZIONE pag. 27

5. PULIZIA pag. 28

6. MANUTENZIONE pag. 29

DIMENSIONI pag. 30

1. REGOLAZIONE GENERALE

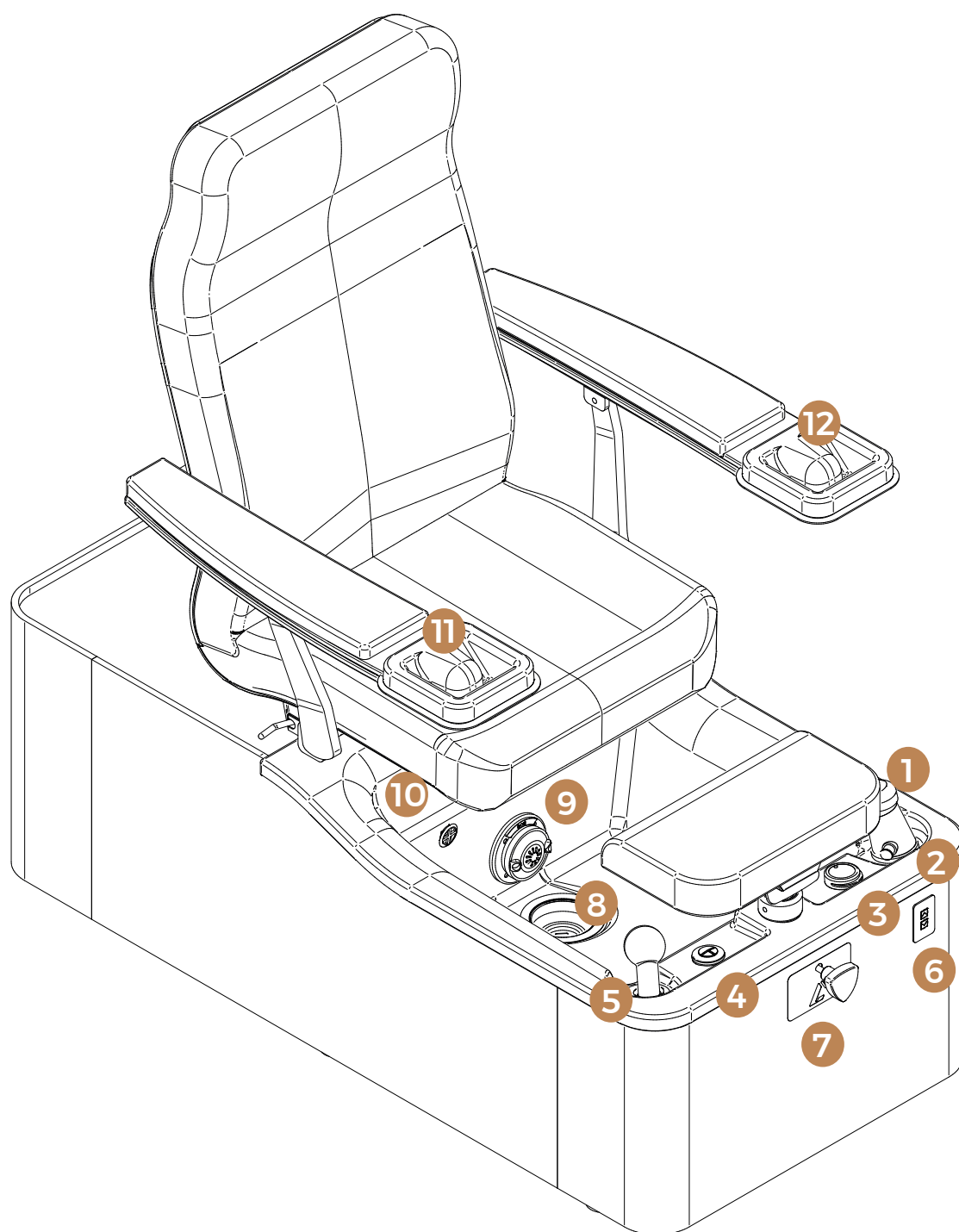

DESCRIZIONE ARTICOLI

- | | |
|--|---|
| 1. Miscelatore temperatura acqua (rubinetto) | 7. Manopola regolazione verticale poggiatesta |
| 2. Deviatore per doccia manuale | 8. Scarico |
| 3. Manopola scarico | 9. Motore (girante) |
| 4. Pulsante di avviamento | 10. Scarico Troppo pieno |
| 5. Doccia manuale | 11. Telaio vaschetta poggia mani |
| 6. Pulsante regolazione seduta | 12. Vaschetta poggia mani |

2. INSTALLAZIONE

2.1 Posizionamento

Importante: CAPRI / ELBA PediSpa sono state progettate per essere installate come unità fisse e devono essere posizionate in una struttura appropriata e su pavimento stabile.

L'intera attrezzatura contenente acqua a livello di lavoro, pesa circa 141 Kg.

Si raccomanda di consultare un tecnico prima di posizionarla per accertarsi che il supporto sia idoneo.



ATTENZIONE! Capri / Elba PediSpa è dotata di 4 piedini regolabili perimetrali. E' importante che tutti e 4 i piedini siano regolati per livellare ogni imperfezione del pavimento.



ATTENZIONE! Per il posizionamento in cabina o per spostare la vostra Capri / Elba PediSpa posizionare le mani al di sotto del carter di legno impugnando il telaio metallico sottostante.



NON SOLLEVARE MAI CAPRI / ELBA PEDISPA IMPUGNANDO SOLO IL CARTER DI LEGNO.

2.2. Smontaggio carter di legno



ATTENZIONE! Capri / Elba PediSpa vi sarà consegnata con la vasca separata dalla poltrona come da figura sottostante.



2.3. Smontaggio base



PASSO 1: Rimuovere l'asse di copertura



PASSO 2: Svitare le 4 viti con l'apposita chiave per togliere il carter di legno posteriore



PASSO 3: Sfilare il carter di legno posteriore



PASSO 4: Sfilare l'asse laterale sinistro

2.4. Collegamenti idraulici



ATTENZIONE! Tutti i collegamenti idraulici devono essere realizzati da un idraulico secondo le normative nazionali vigenti.



ATTENZIONE! Prima di collegare l'acqua calda e fredda al sistema di fornitura dell'acqua, far scorrere l'acqua per accertarvi che tutti i residui escano dalle tubazioni interne.

COLLEGAMENTI:

- I collegamenti dell'acqua calda e fredda devono essere fatti con tubazioni da 1/2" o equivalenti.
- **ACQUA CALDA** (BORDO ROSSO) 1/2" femmina.
- **ACQUA FREDDA** 1/2" femmina.



IMPORTANTE: I collegamenti idraulici (scarico) sono in PVC flessibile Ø40 mm.

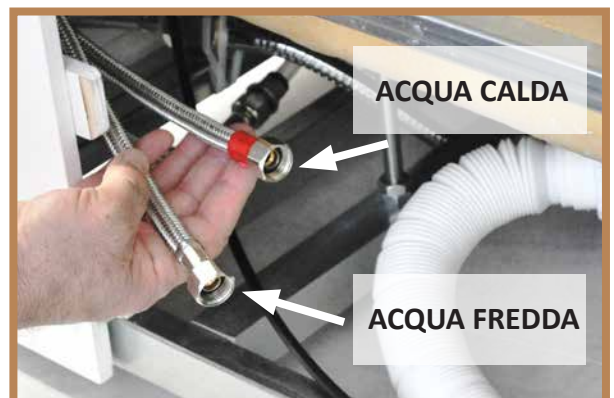

N.B: per un regolare deflusso dell'acqua consigliamo lo scarico a pavimento Ø40 mm il più basso possibile (filo pavimento).

I collegamenti devono essere realizzati secondo le richieste delle normative nazionali vigenti.

Vi raccomandiamo l'utilizzo di piastrelle antiscivolo sul pavimento circostante. Oltre al tubo di scarico della Capri PediSpa, raccomandiamo di inclinare il pavimento verso un secondo scarico in caso di spargimento d'acqua. **Queste precauzioni assicureranno un ambiente sicuro sia al cliente che all'operatore.**



2.5. Collegamenti elettrici

Inserire la spina in una presa elettrica idonea per mettere in funzione l'apparecchiatura.



ATTENZIONE: se c'è incompatibilità tra la presa e la spina dell'attrezzatura, fare sostituire la presa con un tipo adatto da personale professionalmente qualificato. Estrarre la spina dalla presa afferrando la spina e non il cavo.

2.6. Installazione della poltrona



PASSO 1: Svitare la vite presente sul perno della poltrona



PASSO 2: Per montare la poltrona sulla vasca impugnare la base e la parte metallica che collega il bracciolo alla schiena ed inserire il perno nel foro presente sul telaio metallico.



ATTENZIONE: assicurarsi che l'anello di ottone presente sul perno rimanga al suo posto nell'inserimento della seduta.



PASSO 3: Riavvitare la vite precedentemente svitata dal perno della poltrona.

2.7. Montaggio carter perimetrali



PASSO 1: Rimontare il carter di legno laterale sinistro e destro inserendo la fiancata nell'apposita scanalatura della vasca.



PASSO 2: Rimontare il carter di legno posteriore inserendo nelle apposite guide e facendo pressione ai lati.



PASSO 3: Fissare il carter di legno posteriore riavvitando le 4 viti (2 superiori e 2 inferiori) con l'apposita chiave.



PASSO 4: Richiudere la parte superiore sotto la seduta.

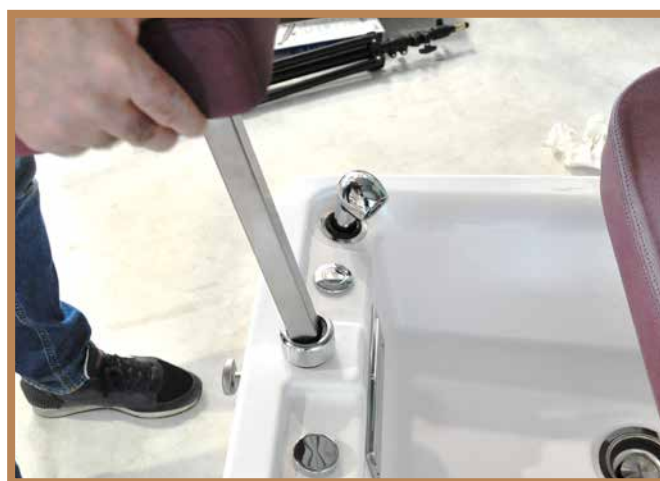

PASSO 5: Posizionare il poggiatesta inserendo il perno nell'apposito foro. Per la regolazione del poggiatesta vedere "3. Procedure operative".

3. PROCEDURE OPERATIVE DI UTILIZZO

3.1. Utilizzo rubinetto

Assicuratevi che la vasca sia perfettamente pulita e sterilizzata prima di riempirla.
Per riempire la vasca aprire il rubinetto e regolare la temperatura dell'acqua ruotando la manopola verso destra per il caldo, sinistra per il freddo.



**NON AZIONARE L'IDROMASSAGGIO IN ASSENZA DI ACQUA NELLA VASCA.
IL LIVELLO DI ACQUA DEVE SEMPRE COPRIRE LA GIRANTE.**

3.2. Utilizzo e manutenzione dell'apparecchiatura

RIEMPIMENTO AUTOMATICO DELLA VASCA E ACCENSIONE DELL' IDROMASSAGGIO (SOLO PER CAPRI PEDI SPA)

Premere il pulsante **AUTO FILL** per il riempimento automatico della vasca (sensore fino al livello pre impostato).
Al raggiungimento del livello la fuoriuscita dell'acqua si interrompe automaticamente, dopodiché il getto d'aria (idromassaggio) si accende automaticamente.

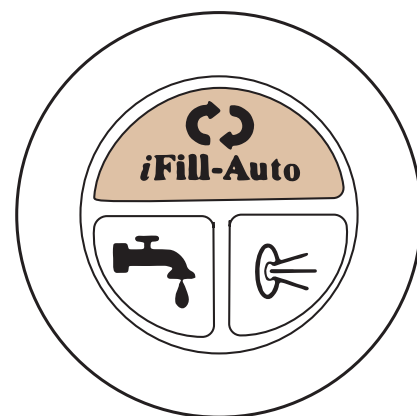

RIEMPIMENTO MANUALE DELLA VASCA (SOLO PER CAPRI PEDI SPA)

Premere il pulsante **RUBINETTO** per il riempimento manuale della vasca. Per fermare l'uscita dell'acqua, premere nuovamente lo stesso pulsante.



**IL LIVELLO DI ACQUA DEVE
SEMPRE COPRIRE LA GIRANTE.**

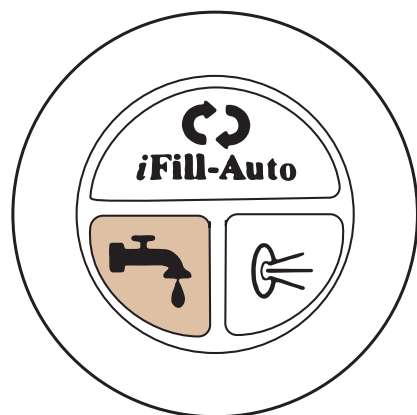

AVVIAMENTO IDROMASSAGGIO

Una volta che la vasca è stata riempita d'acqua, attivare la pompa per avviare il movimento massaggiante in acqua premendo il pulsante con l'icona **GETTO**.

AVVIAMENTO IDROMASSAGGIO (PER ELBA PEDI SPA)

Per attivare l'idromassaggio su **Elba Pedi Spa**, premere il pulsante intero.

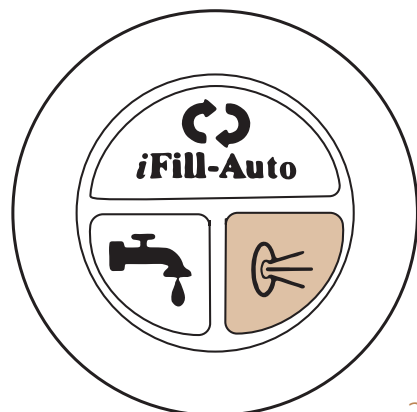



ATTENTION!

IL LIVELLO DI ACQUA DEVE SEMPRE COPRIRE LA GIRANTE (A).

Infatti, dopo 30 SECONDI che la pompa funziona A SECCO (B) o con un LIVELLO PARZIALE DI ACQUA (C), LA GIRANTE SI SURRISCALDA E SI ROVINA, diventando inutilizzabile. Qualsiasi intervento effettuato sulla macchina a seguito di errato utilizzo delle presenti istruzioni, non sarà da considerarsi in garanzia.



A. Il livello di acqua deve SEMPRE COPRIRE LA GIRANTE



B. Condizione della girante rovinata per ASSENZA DI ACQUA



C. Condizione della girante rovinata per RIEMPIMENTO PARZIALE

3.3. Procedura di RESET centralina (SOLO per CAPRI PEDI SPA)

Nel caso in cui la vostra Capri PEDI Spa abbia problemi di funzionamento, in particolare con il sistema iFill-Auto di riempimento automatico, vi suggeriamo di procedere con la seguente procedura di reset.

1) Togliere tensione per qualche secondo alla macchina, aspettare qualche secondo e poi collegare nuovamente la Capri PEDI Spa alla corrente elettrica.

Premere e tenere premuto il pulsante iFill-Auto di riempimento automatico fino a quando non emetterà un suono prolungato e non appena verrà rilasciata la pressione i led inizieranno a lampeggiare

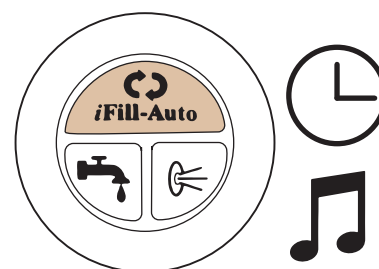

2) Dopo aver udito il suono, **premere il pulsante del funzionamento dell'idromassaggio.**

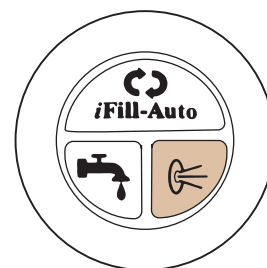

3.4. Pulizia della girante

1. Rimuoverla dalla vasca
2. Ruotare le 2 cover in plastica fino allo sgancio
3. Separare le 2 parti in plastica
4. Estrarre la ventolina interna
5. Procedere alla pulizia:
 - 5.1. Posizionare le cover e la ventolina in una bacinella con circa 20 cl di detergente Saniguest
 - 5.2. Coprire con acqua pulita
 - 5.3. Lasciare in ammollo per circa 2 ore
 - 5.4. Asciugare con panno morbido. Non usare spugne abrasive
6. Rimontare le parti
7. Posizionare il getto sulla vasca



3.5. Posizionare la girante

La girante va posizionata con i fori in orizzontale. Avvicinare la girante alla vasca, grazie alla presenza del magnete il pezzo si salderà alla base della vasca.



3.6. Utilizzo doccino manuale

Per utilizzare il doccino manuale tirare il deviatore posizionato alla sinistra del rubinetto e ruotarlo per bloccarlo. In questo modo l'acqua verrà deviata al doccino manuale. Una volta terminato l'utilizzo del doccino manuale riporlo nell'apposito foro (a sinistra della vasca).



3.7. Utilizzo scarico

Ruotare la manopola verso destra o verso sinistra per aprire o chiudere lo scarico.



3.8. Regolazione poggia piedi

Il poggiapiedi è regolabile sia in altezza che in profondità.

Per modificare l'altezza, svitare la manopola presente sulla parte frontale del carter di legno e regolare la posizione del poggiapiedi.

Trovata la giusta altezza, stringere la manopola per fissare il poggiapiedi in posizione.



Per regolare avanti o indietro il poggipiedi, con una mano ruotare il pomolo presente sotto il poggipiedi, con l'altra aggiustare la posizione. Stringere il pomolo per bloccare il poggipiedi.

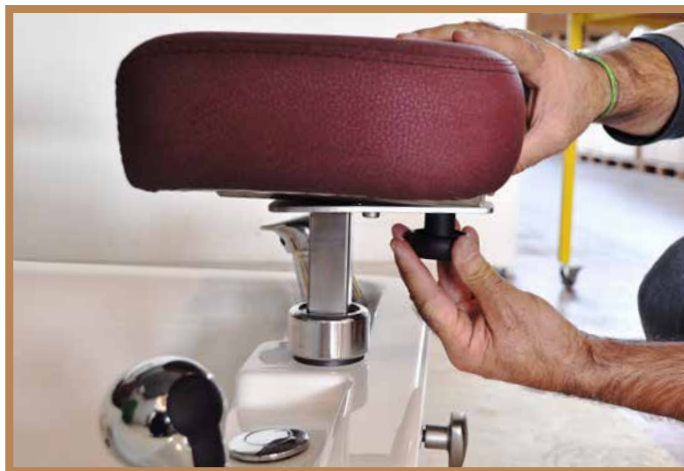

3.9. Regolazione seduta ed inclinazione

La seduta è regolabile elettricamente. Per regolare la seduta in profondità (più avanti o più indietro) premere i 2 pulsanti presenti sulla parte frontale del carter di legno.



Per regolare l'inclinazione della seduta, con una mano tirare la levetta presente sul lato destro della macchina, con l'altra premere sullo schienale della seduta.

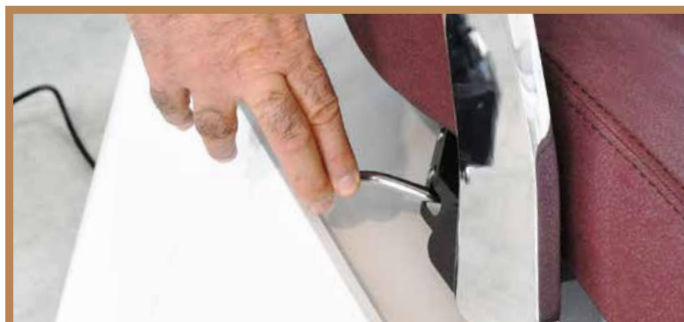

Rilasciare la leva per fissare la posizione

3.10. Regolazione rotazione seduta

La poltrona può ruotare di 180° da un lato e dall'altro per facilitare l'accesso al cliente, semplicemente muovendola finché arriva a fine corsa, sia da un lato che dall'altro.



ATTENZIONE! Al cliente non andrebbe mai permesso di entrare o uscire dalla postazione se non in posizione "ruotata".

3.11. Posizionamento vaschette

Posizionare il telaio metallico nel foro predisposto sui braccioli. Infilare la vaschetta poggia mani sul telaio.



4. SCHEMA DI INSTALLAZIONE

4.1. Allacciamento rete elettrica/idrica

PORTATA IMPIANTO ELETTRICO:

Voltaggio 220v 2 fasi + terra

Presenza 10A min

PORTATA IMPIANTO IDRICO:

8 litri / minuto

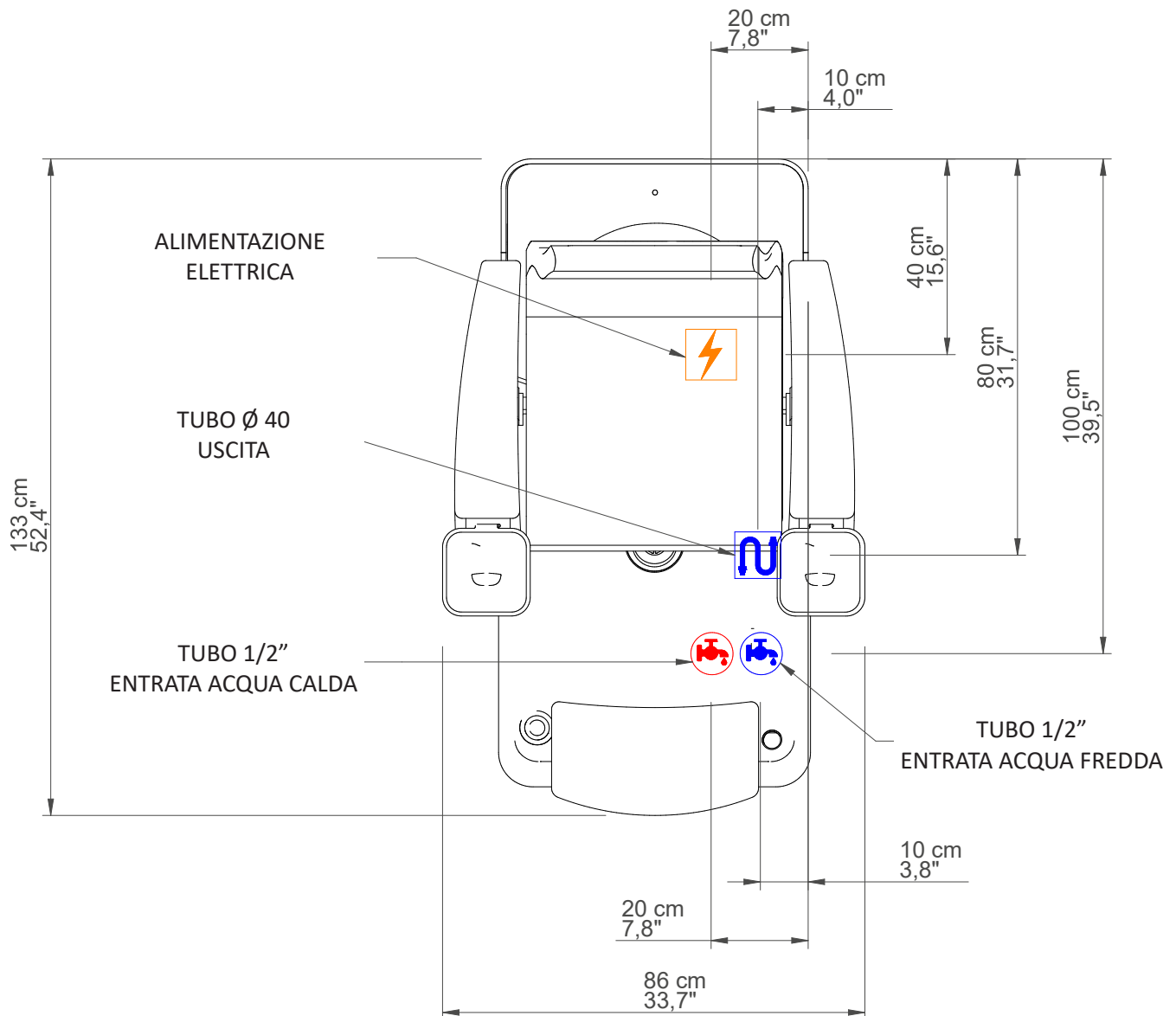

ATTENZIONE! Per SCARICO A PARETE, va aggiunta la POMPA DI SCARICO (OPTIONAL)



ATTENZIONE!

Il KIT Scarico Parete viene montato all'interno del carter della PediSpa e si collega all'esterno mediante tubo in gomma tipo LIGURIA Ø 22mm lungo 3m.

5. PULIZIA

PULIZIA VASCA VETRORESINA



NON utilizzare assolutamente i seguenti prodotti che potrebbero aggredire la vasca, provocando la formazione di crepe e quindi la rottura:

- Agenti sgrassanti a base di solventi quali ad esempio: ACETONE, ALCOOL ETILICO DENATURATO, TRIELINA, BENZINA, ACQUARAGIA...
- Acidi diluiti in soluzione acquosa (ACIDO CLORIDRICO, ACIDO NITRICO ...) e prodotti contenenti acidi diluiti
- Basi diluite in soluzione acquosa (SODA CAUSTICA, IPOCLORITO DI SODIO, AMMONIACA, CANDEGGINA) e prodotti contenenti basi deboli
- Idrocarburi fluorurati (esempio PERDITE DI GAS FRIGORIFERI)
- Oli alimentari (esempio OLIO DI OLIVA, OLIO DI SEMI)
- Oli lubrificanti a base minerale



Per la PULIZIA della vasca consigliamo:

- Acqua saponata (sapone neutro)
- Spugna morbida

Procedere sempre al risciacquo con acqua pulita e asciugatura con panno morbido non abrasivo.

PULIZIA SEDUTA

Ogni volta che effettuate un trattamento, vi suggeriamo di coprire la poltrona con salviette o teli monouso prima di far salire il cliente.



Prestate particolare attenzione al jeans che può macchiare il rivestimento senza alcuna possibilità di essere rimosso.



Pulire il lettino prima di ogni utilizzo, prestando particolare attenzione a rimuovere qualsiasi traccia di eventuali liquidi fisiologici del paziente precedente.



Per la pulizia della poltrona utilizzare un panno e acqua tiepida (eventualmente detersivo neutro diluito). Se necessario, utilizzare un disinfettante non aggressivo, quindi ripassare subito con un panno asciutto e pulito. Non usare prodotti come: alcool, acetone, candeggina, diluente, benzina.

MANTENIMENTO

1) Da effettuarsi DOPO di ogni singolo trattamento/cliente:

Al termine di ogni singolo trattamento, scaricare l'acqua e spruzzare l'apposito detergente SANIGUEST all'interno della vasca. Pulire utilizzando una spugna morbida e risciacquare con l'apposita doccia manuale.

2) Da effettuarsi PERIODICAMENTE (ogni 1-2 settimane in base alle caratteristiche dell'acqua utilizzata).

Spruzzare l'apposito liquido disincrostante GO KAL nella vasca, prestando molta attenzione al contatto con mani e occhi. Lasciare agire qualche minuto e strofinare la vasca con una spugna morbida. Prima di risciacquare abbondantemente con l'apposita doccia manuale, far scorrere per qualche secondo acqua dall'impianto di riempimento per eliminare ogni traccia di calcare anche dai getti.



**NON UTILIZZARE MAI DETERGENTI CREMOSI O IN POLVERE, SPUGNE O PANNI ABRASIVI.
NON UTILIZZARE CANDEGGINA O ALTRI PRODOTTI CORROSIVI PER LA PULIZIA DELLA POLTRONA!**

N.B. Per ordinare i nostri detersivi SANIGUEST E GO KAL, contattate il vostro consulente di zona o chiamate il nostro Servizio Clienti al numero 0374/363069 – mail: orders@lemigroup.it

Seguendo queste semplici istruzioni di pulizia e manutenzione, la vostra vasca resterà pulita, splendente e priva di calcare a lungo.

DIMENSIONI

Dimensioni in cm e pollici

CAPRI PEDI SPA

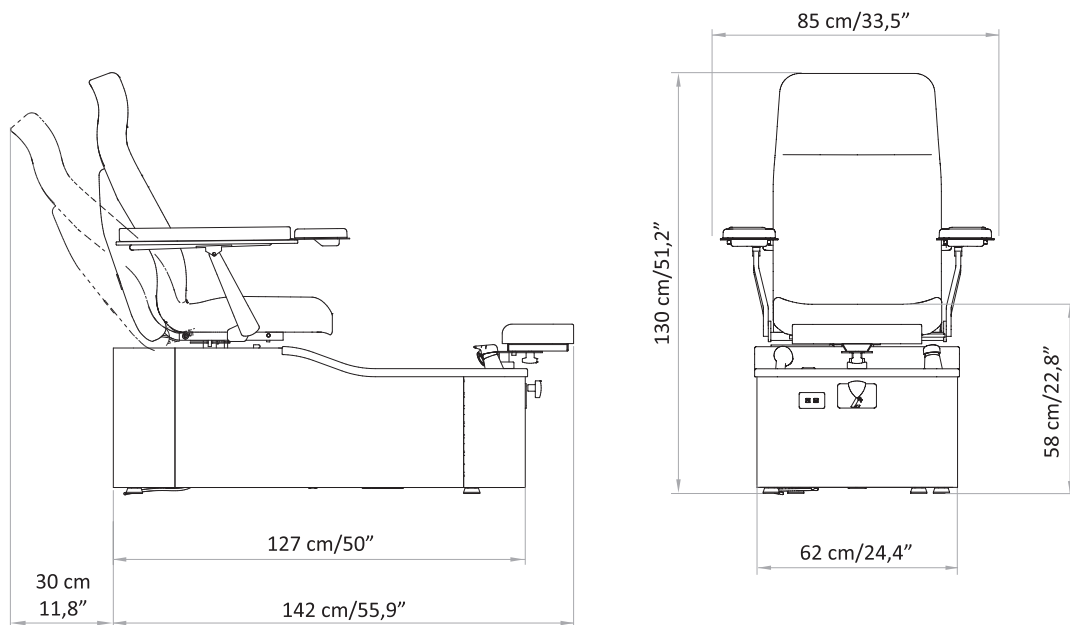

ELBA PEDI SPA

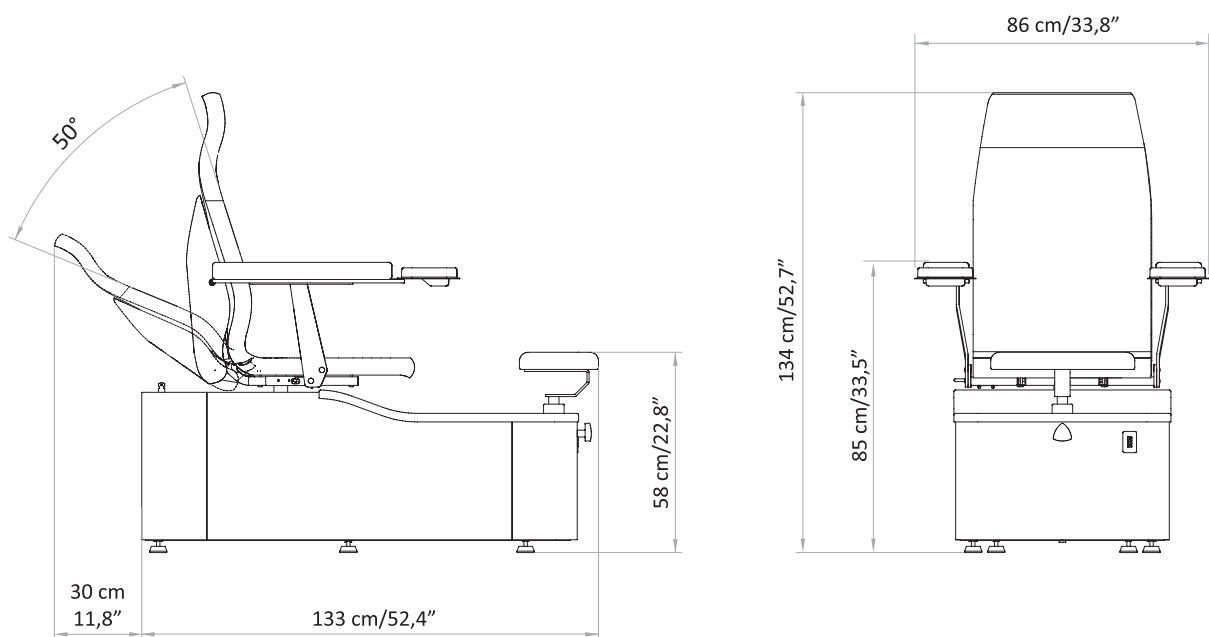

1. DESCRIPTION _____ pag. 4

2. INSTALLATION _____ pag. 5

3. PROCÉDURE D'UTILISATION _____ pag. 9

4. SCHÉMA D'INSTALLATION _____ pag. 13

5. NETTOYAGE _____ pag. 14

6. MAINTENANCE _____ pag. 16

DIMENSIONS _____ pag. 17

1. DESCRIPTION

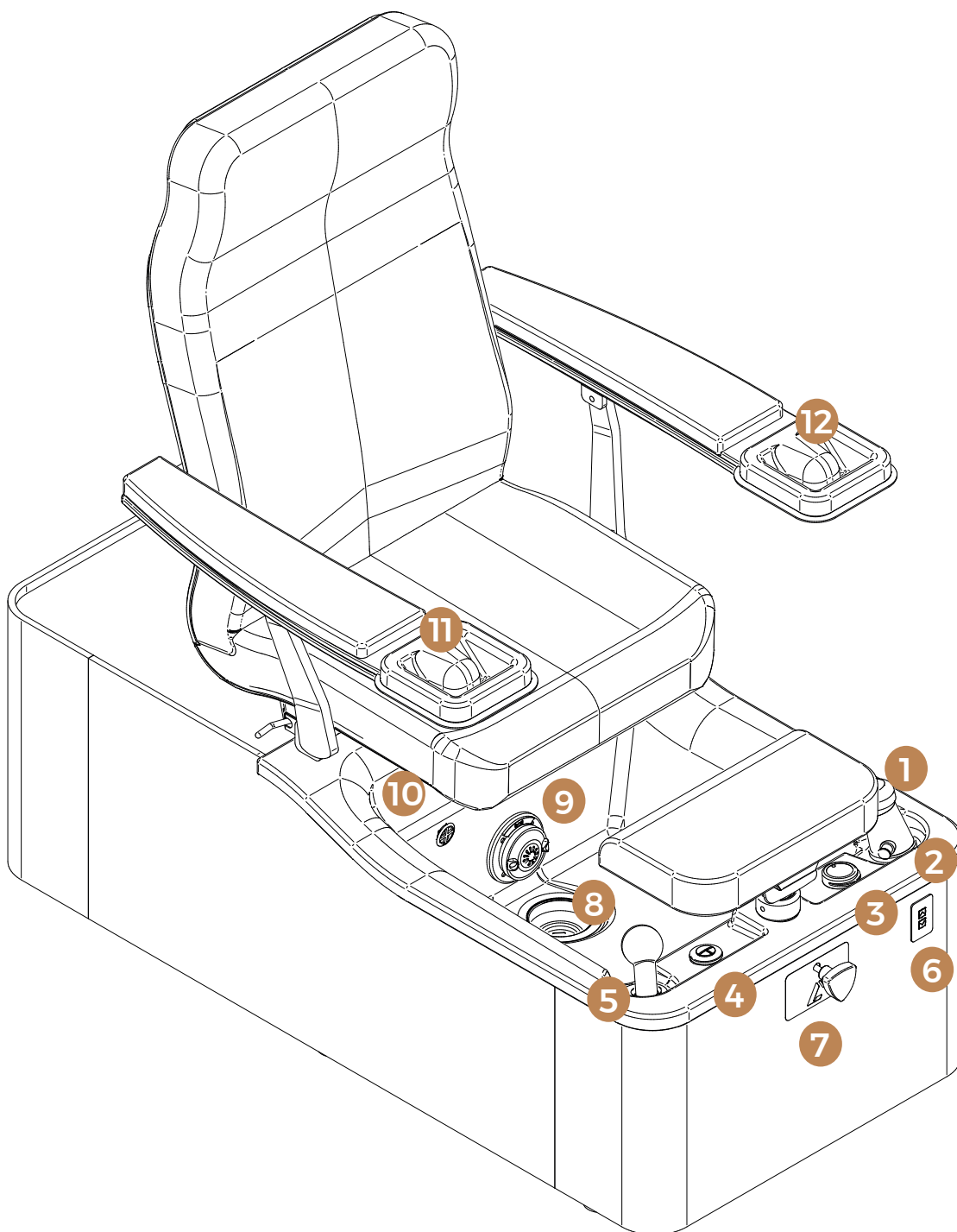

DESCRIPTION

- | | | | |
|----|----------------------------|-----|---------------------------------|
| 1. | Mitigeur | 7. | Poignée réglage support pied |
| 2. | Déviateur douchette à main | 8. | Vidange du bassin |
| 3. | Bouton vidange du bassin | 9. | Moteur Hydro massage Magna Jet |
| 4. | Bouton pour hydro massage | 10. | Vidage trop-plein |
| 5. | Douchette à main | 11. | Support petites bassin manucure |
| 6. | Bouton réglage de l'assise | 12. | Petite bassin manucure |

2. INSTALLATION

2.1. Positionnement

Important: Important: CAPRI / ELBA Pedi Spa été conçue pour être installée comme unité fixe, par conséquent elle doit être positionnée dans une structure appropriée et sur un plancher stable.

L'équipement complet contenant l'eau pèse environ 141 Kg.

On conseille de consulter un technicien avant de le positionner pour s'assurer que le support d'appui soit convenable.



ATTENTION! Capri / Elba Pedi Spa est équipée de 4 pieds réglable. Il est fondamental que tous les 4 pieds soient réglés pour égaliser toutes les imperfections du sol.



ATTENTION! Pour le positionnement dans la cabine ou le déplacement, prendre le châssis en métal du bassin.



NE JAMAIS LEVER CAPRI PEDISPA EN LA PRENANT PAR LE CARTER EN BOIS.

2.2. Démontage du carter en bois



ATTENTION! Capri / Elba PediSpa est livrée en deux cartons, le bassin séparé de la chaise comme dans la photo ci-dessous.



2.3. Démontage de la base en bois



STEP 1: Enlever la couverture supérieure



STEP 2: Dévisser les 4 vis avec la clé spécifique pour enlever la couverture postérieure.



STEP 3: Enlever la couverture postérieure.



STEP 4: Enlever la couverture latérale.

2.4. Branchements Hydrauliques



ATTENTION! Les branchements hydrauliques doivent être réalisés par un plombier selon les réglementations nationales en vigueur.



ATTENTION! Avant de raccorder l'eau froide et chaude au système de fourniture d'eau il faut faire sortir l'eau pour s'assurer que tous les résidus sortent des tuyauteries internes.

BRANCHEMENTS:

-Tuyaux pour eau chaude/froide doivent être 1/2" ou pareil.

-EAU CHAUDE (ROUGE) 1/2" femelle

-EAU FROIDE 1/2" femelle



IMPORTANT: Les tuyaux vidange est Ø 40 mm flexible.

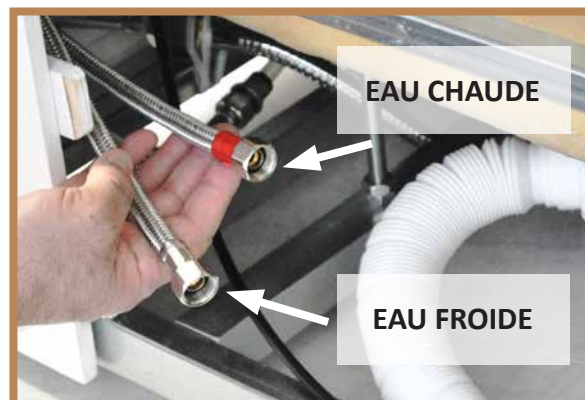

N.B: Pour un bon écoulement de l'eau nous conseillons de placer le tuyau de vidange Ø40 au plus bas possible (niveau du sol).

Les branchements doivent s'effectuer selon les réglementations nationales en vigueur.

On vous conseille l'utilisation de carreaux antiglisse pour le plancher. Outre le tuyau d'évacuation, on conseille d'incliner le plancher aussi vers un deuxième évacuateur en cas d'épandage d'eau.

Ces précautions vont assurer un environnement sûr pour les clients aussi bien que pour les professionnels.



2.5. Raccordements électriques

Insérer la fiche de l'équipement dans une prise de courant adéquate.



ATTENTION: S'il y a incompatibilité entre la prise et la fiche de l'équipement, faire changer la prise avec le modèle désiré par du personnel qualifié. Prendre la fiche et pas le câble pour débrancher l'équipement.

2.6. Installation de la chaise



STEP 1: Dévisser la vis qui se trouve sur le pivot de l'assise.



STEP 2: Pour fixer la chaise au bassin, prendre le châssis en métal de l'assise et insérer le pivot en correspondance du trou sur le bassin.



IMPORTANT: S'assurer que l'anneau en laiton qui se trouve sur le pivot reste dans la position initiale quand il est inséré dans le bassin.



STEP 3: Visser pour fixer la chaise.

2.7. Assemblage des couvertures péricentrales en bois



STEP 1: Placer le carter latérale droit et gauche comme montré dans la photo.



STEP 2: Assembler le carter postérieur en pressant pour le fixer.



STEP 3: Fixer le carter postérieur en dévissant les 4 vis (2 supérieures et 2 inférieures) avec le bon outil.



STEP 4: Placer le carter supérieur

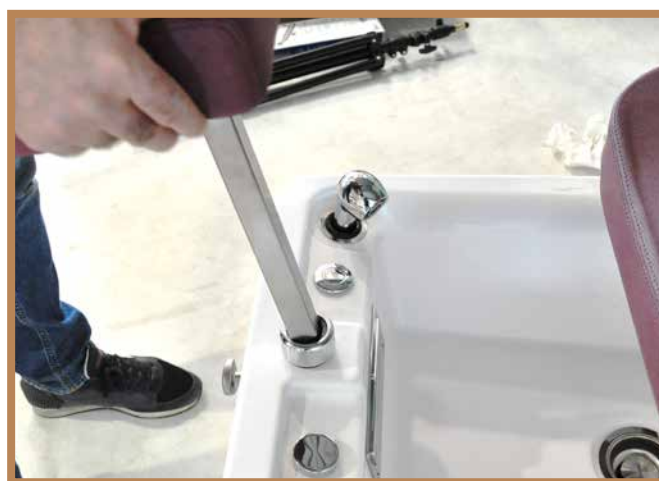

STEP 5: Positionner le support pied comme montré en photo. Pour l'utilisation, consulter le paragraphe « 3. Procédure d'utilisation »

3. PROCÉDURE D'UTILISATION

3.1. Remplissage du bassin

Avant de remplir avec de l'eau l'équipement, vérifier que le bassin soit propre and stérilisé et qu'aucun déchet ne se trouve dans le bassin même. Risque d'éraflures.

Ouvrir le mitigeur et régler la température de l'eau en le tournant droite pour eau chaude ou gauche pour eau froide.



**N'ACTIVER PAS L'HYDRO MASSAGE SANS EAU.
LE NIVEAU D'EAU DOIT TOUJOURS COUVRIR LE MOTEUR HYDRO MASSAGE « MAGNA JET ».**

3.2. Utilisation et maintenance

REPLISSAGE AUTOMATIQUE DU BASSIN ET ACTIVATION DE L'HYDRO MASSAGE (SEULEMENT POUR CAPRI PEDI SPA)

Presser le bouton **AUTO FILL** pour remplir automatiquement le bassin (capteur déjà réglé).

Quand l'eau arrive au niveau établi, l'eau se ferme et les jets d'aire (hydro massage) s'activent automatiquement.

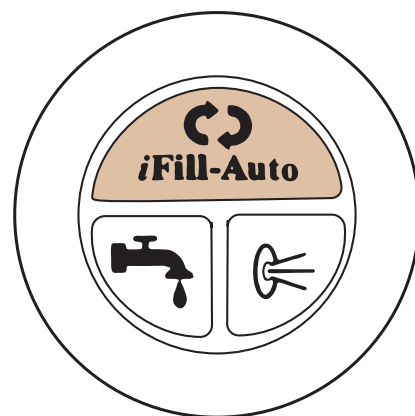

REPLISSAGE MANUEL DU BASSIN (SEULEMENT POUR CAPRI PEDI SPA)

Presser le bouton **TAP** pour le remplissage manuel du bassin. Pour fermer la sortie de l'eau, presser encore le même bouton.

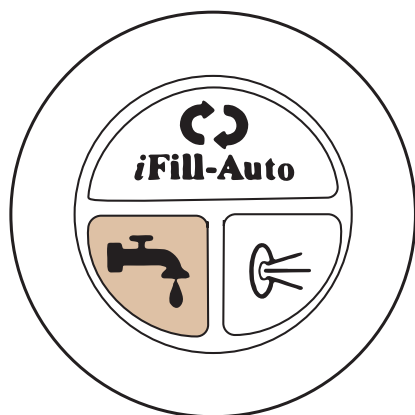

LE NIVEAU DE L'EAU DOIT TOUJOURS COUVRIR LE MOTEUR HYDRO MASSAGE « MAGNA JET »

HYDROMASSAGE

Pour l'activation manuelle de l'hydro massage presser le bouton avec l'icône **PUMP**, une fois que l'eau a reçu le niveau du « Magna Jet ».

HYDROMASSAGE (POUR ELBA PEDI SPA)

Pour activer l'hydro massage sur Elba Pedi Spa presser tout le bouton.

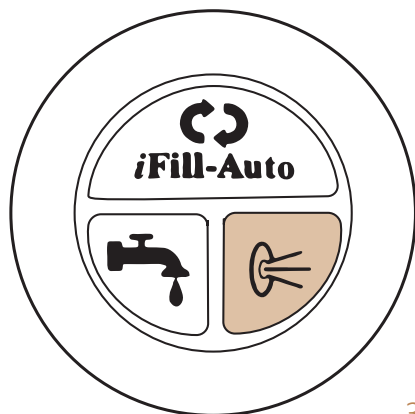



ATTENTION!

L'EAU DOIT TOUJOURS COUVRIR LE MOTEUR HYDRO MASSE « MAGNA JET » (A)

car après 30 SECONDS que le moteur fonctionne sans eau (B) ou bien avec eau insuffisante (C) il y a le risque de surchauffe du moteur même.

Tous remplacements effectués pour usage incorrect de l'équipement seront considérés hors garantie.



A. Le niveau de l'eau doit **TOUJOURS COUVRIR** le moteur hydro massage



B. Condition du moteur en cas de fonctionnement sans d'eau



C. Condition du moteur en cas de fonctionnement avec d'eau partielle

3.3. Procédure de RESET (SEULEMENT POUR CAPRI PEDISPA)

Dans le cas Capri PediSpa à des problèmes de fonctionnement, en particulier avec le remplissage automatique iFill Auto Fill, nous suggérons de procéder avec la procédure de remise à zéro.

1) Débrancher l'équipement du 220V pour quelque second et brancher de nouveau à la prise de courante.

Presser et maintenir pressé le bouton de remplissage automatique iFill-Auto jusqu'à quand on entend un son prolongé. Lever la pression du bouton: les voyants led commencent à clignoter.

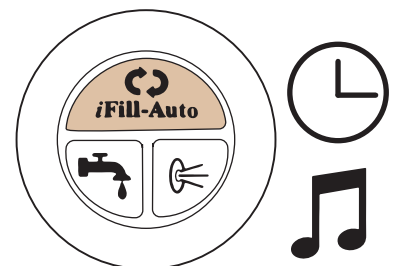

2) Après le son prolongé, **presser le bouton pour allumer l'hydromassage**

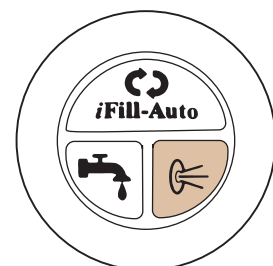

3.4. Nettoyage moteur hydro massage « Magna Jet »

1. Enlever le « Magna Jet »
2. Pivoter les 2 couvercles pour ouvrir
3. Séparer les 2 couvercles
4. Enlever la petite hélice
5. Procéder au nettoyage:
 - 5.1. Plonger les deux couvercles en plastique et la petite hélice dans un récipient avec 20 cl de détergent Saniguest
 - 5.2. Couvrir avec de l'eau
 - 5.3. Laisser tremper pour 2h
 - 5.4. Sécher avec une toile souple, n'utiliser pas des éponges abrasives
6. Assembler le « Magna Jet » (2 couvercles en plastique + 1 petite hélice)
7. Placer le « Magna Jet » sur le bassin (voir 3.5. Position correcte du « Magna Jet »)



3.5. Position correcte du « Magna Jet »

Placer le « Magna Jet » avec les trous en horizontal. Les composants se fixent grâce à l'aimant.



3.6. Emplois de la douchette à main

Pour utiliser la douchette à main, tirer le déviateur qui se trouve sur le mitigeur et tourner pour fixer. De cette manière l'eau va sortir de la douchette à main. Positionner la douchette à main dans son support quand elle n'est pas utilisée.



3.7. Vidange

Tourner droite / gauche pour fermer ou bien ouvrir le vidange de l'eau.



3.8. Réglage du support pied

Pour régler la hauteur, dévisser en sens antihoraire le pommeau et régler le support pieds. Visser en sens contraire pour fixer la position.



Pour glisser en avant/arrière le support pied, tourner le pommeau noir.

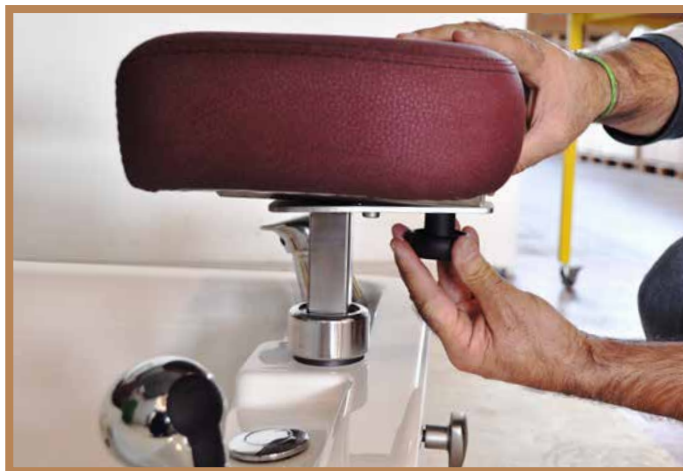

3.9. Réglage de la chaise

La chaise se règle en avant/arrière automatiquement. Presser les boutons qui se trouvent devant le bassin.



Pour récliner le dossier de la chaise, tirer le levier qui se trouve sur la droite de la chaise et régler. Laisser le levier pour fixer la position.

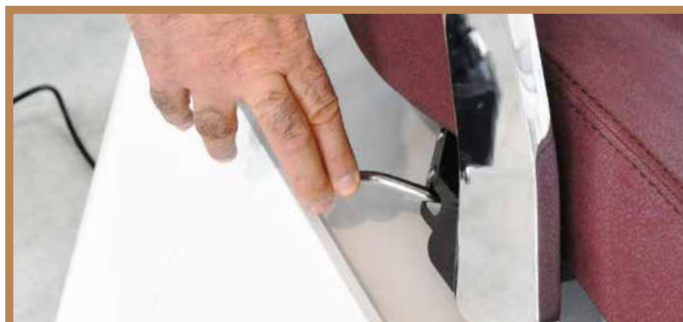

3.10. Rotation de la chaise

La chaise peut pivoter 180° droite et gauche pour faciliter l'accès au client.



ATTENTION! Le client doit s'asseoir ou descendre de la chaise seulement quand elle se trouve dans la position latérale (pivoté).

3.11. Positionnement des bacs manucure

Placer les supports en métal sur chaque accoudoir. Positionner les bacs dans les supports.



4. SCHÉMA D'INSTALLATION

4.1. Branchement électrique/hydraulique

SYSTÈME ÉLECTRIQUE

Voltage 220V 2 phases + terre

Prise 10A min

SYSTÈME HYDRAULIQUE

8 Litres / minute

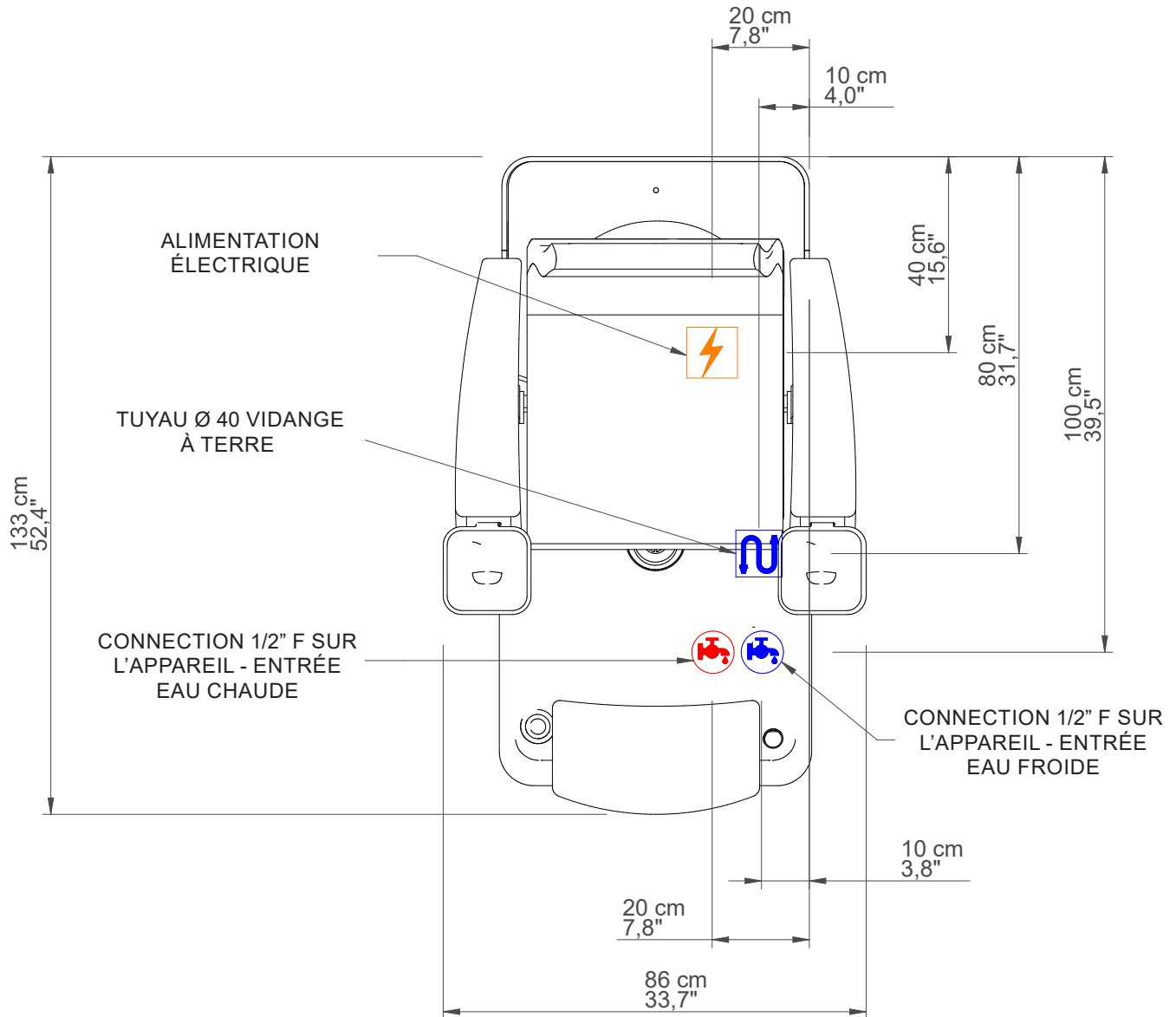

ATTENTION! En cas de vidange d'eau se trouve au mur et pas à terre, la pompe de vidange (optionnel) est nécessaire.



ATTENTION!

Le KIT de Vidange Murale est monté à l'intérieur du carter du fauteuil et est relié à l'extérieur par un tuyau en caoutchouc de type LIGURIA Ø 22mm d'une longueur de 3m

5. NETTOYAGE

BASSIN



Il est interdit d'utiliser les produits suivants qui pourraient endommager le revêtement du bassin en résine et fibre de verre :

- Agents de dégraissage à base de solvants : ACÉTONE, ALCOOL EXILIQUE DÉNATURE, TRICHLORÉTHYLÈNE, CARBURANT, TURPENTINE...
- Bases diluées (SODA CAUSTIQUE, HYPOCHLORITE DE SODIUM, AMMONIAQUE, EAU DE JAVEL) ou produits contenant es bases faibles
- Hydrocarbures fluorés (par exemple, FUITES DE GAZ RÉFRIGÉRANT)
- Huiles de qualité alimentaire (par exemple HUILE D'OLIVE, HUILE DE GRAINES)
- Huiles lubrifiantes à base de minéraux



Pour NETTOYER le bassin nous suggérons, donc :

- Eau savonneuse (savon neutre)
- Rincer avec éponge souple ou chiffon doux, non abrasif.

Toujours rincer à l'eau propre et sécher avec un chiffon doux et non abrasif.

NETTOYAGE DE LA CHAISE

Nous suggérons de toujours couvrir la chaise avec une serviette ou bien de toiles jetables avant que le client s'assoit.



Faire attention en particulier au jeans qui peut tacher le revêtement en manière irrévocable.



Avant chaque traitement, essuyer immédiatement tous liquides qui pourraient finir sur la chaise.



Pour le nettoyage utiliser un chiffon et de l'eau tiède (éventuellement un produit de nettoyage neutre dilué). Si nécessaire utiliser un désinfectant non agressif, ensuite essuyer immédiatement avec un chiffon souple, sec et propre.

Ne pas utiliser de produits contenant Alcool, Acétone, Diluant, Eau de javel, Essence.

MAINTENANCE

1) APRÈS chaque utilisation, **AVANT** chaque traitement

Vider le bassin, vaporiser le désinfectant SANIGUEST et nettoyer avec une éponge souple ou un chiffon doux. Rincer le bassin avec la douchette à main.

2) PÉRIODIQUEMENT (une fois par semaine selon la qualité de l'eau)

VAPORISER le bassin avec le détartrant GO KAL en évitant le contact avec les yeux et la peau. Nettoyer avec une éponge souple ou du chiffon doux. Rincer abondamment et laisser écouler l'eau de jets pour quelques seconds pour éliminer toute trace de calcaire.



IMPORTANT ! Ne pas utiliser de détergent en crème ou abrasifs, désinfectant purs ou éponges abrasives. Ne pas utiliser de blanchissant, eau de javel ou tout autre produit corrosif pour le nettoyage de la chaise.

N.B. Si vous avez la nécessité de commander le détergent SANIGUEST ou le détartrant GO KAL, contacter le fabricant au numéro 0039/0374/36.30.69 ou bien écrivez à orders@lemigroup.it

En observant ces simples instructions de nettoyage et maintenance, votre appareil se conservera en bon état, propre et brillant pour longtemps.

DIMENSIONS

Mesures en cm et inches

CAPRI PEDI SPA

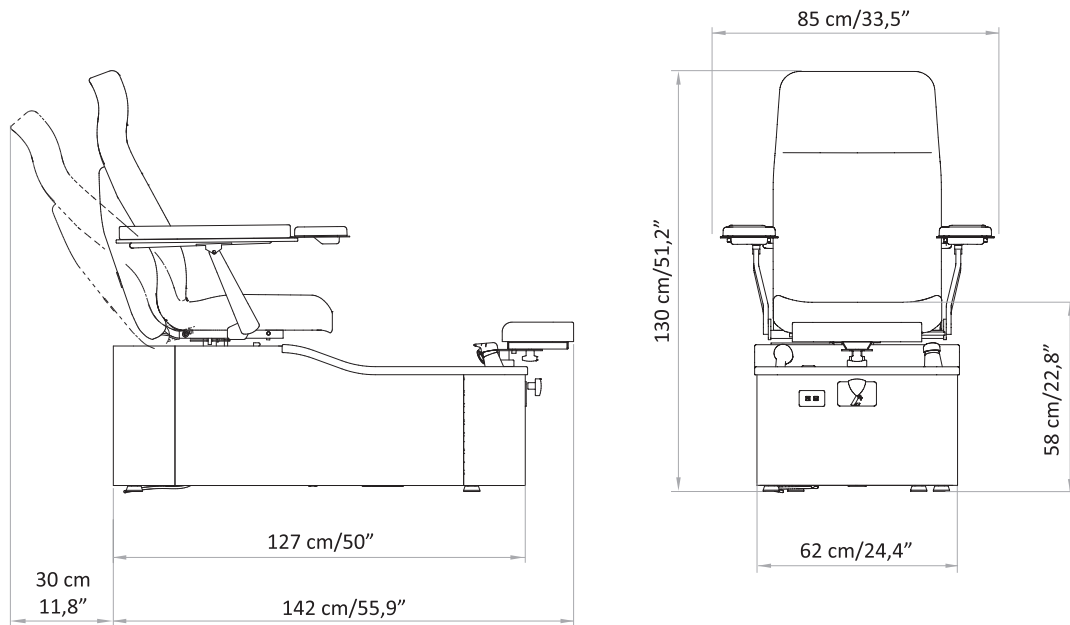

ELBA PEDI SPA

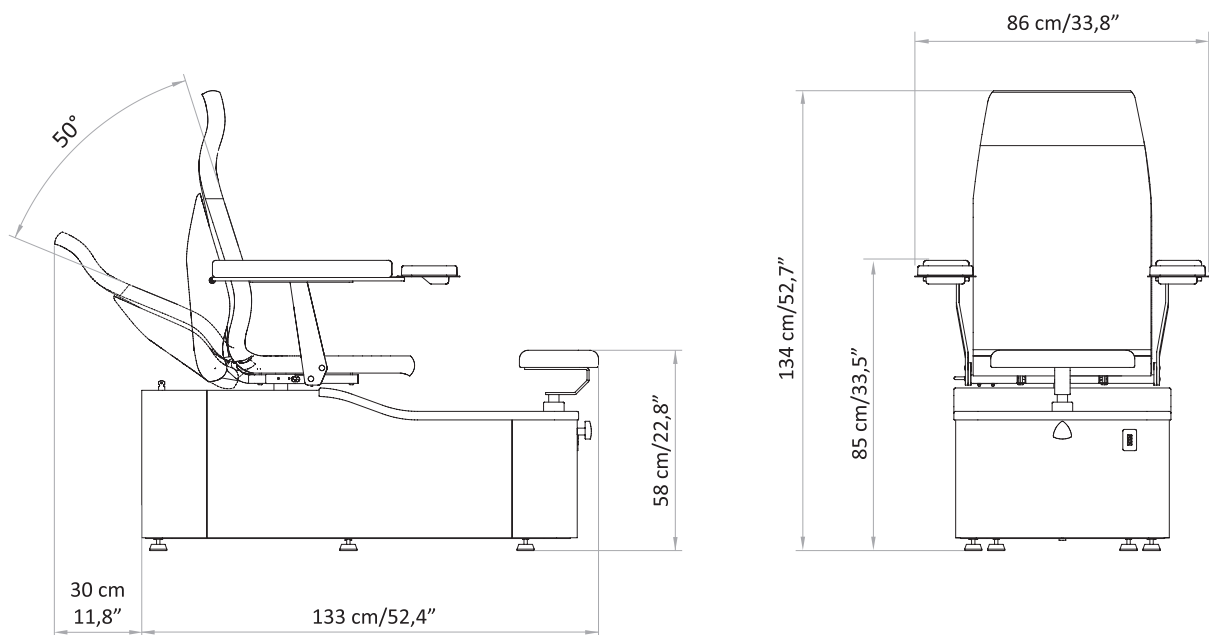

DE- BEDIENUNGSANLEITUNG

1. ALLGEMEINE BESTIMMUNGEN _____ pag. 4

2. POSITIONIERUNG _____ pag. 5

3. ARBEITSANWEISUNGEN _____ pag. 9

4. INSTALLATIONSSCHEMA _____ pag. 13

5. REINIGUNG _____ pag. 14

6. INSTANDHALTUNG _____ pag. 16

AUSSENMASS _____ pag. 17

1. ALLGEMEINE BESTIMMUNGEN

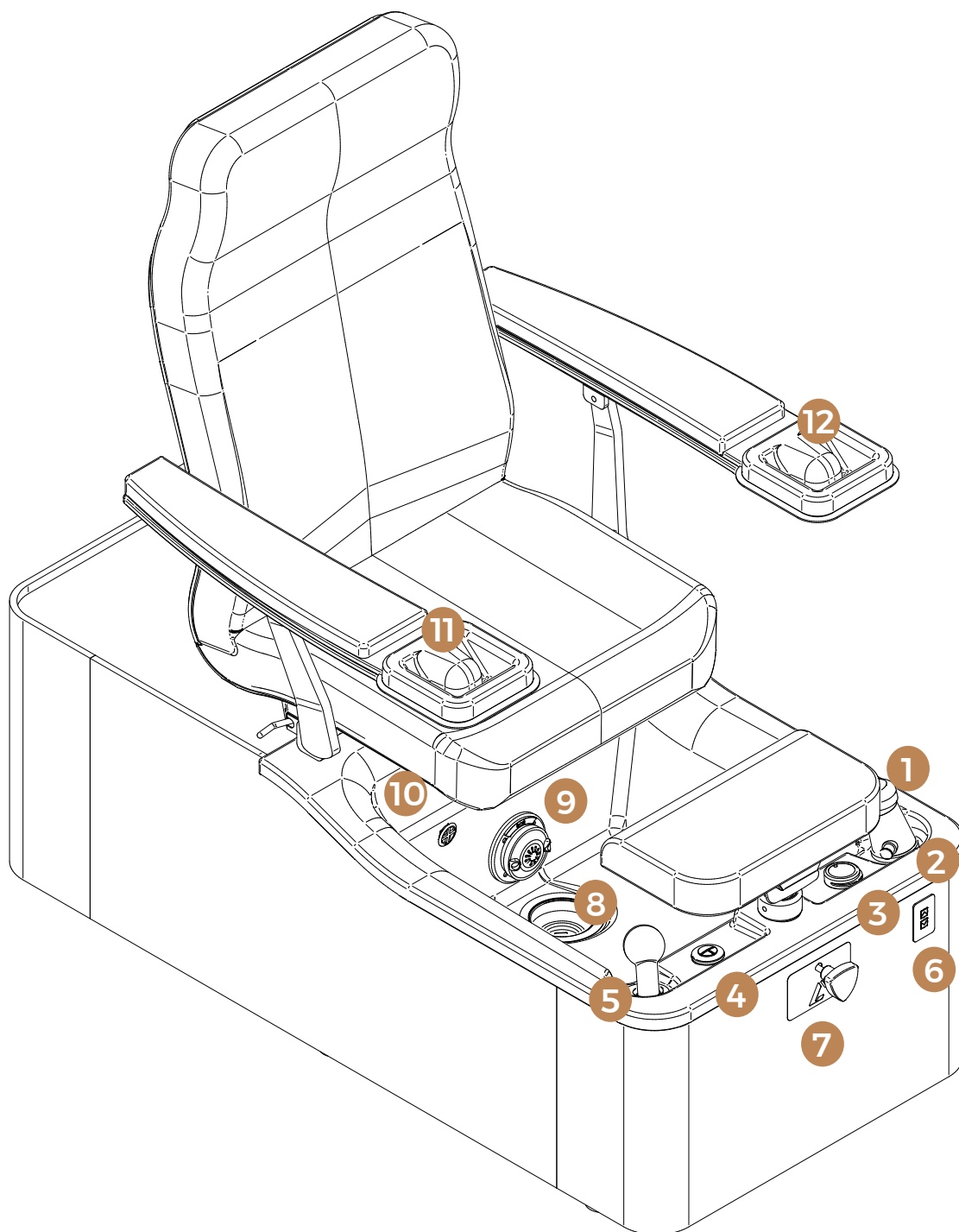

PRODUKTBESCHREIBUNG

- | | |
|---------------------------------------|---|
| 1. Wassertemperaturmischer (Hahn) | 7. Handgriff zur Höhenverstellung der Fußstütze |
| 2. Umsteller für Handbrause | 8. Ablassen |
| 3. Handgriff entleeren | 9. Hydromassage Magna Jet |
| 4. Start Knopf | 10. Voller abfluss |
| 5. Hand dusche | 11. Rahmen der Handauflage |
| 6. Einstellknopf für die Sitzposition | 12. Handauflage |

2. POSITIONIERUNG

2.1. Positionierung

WICHTIG: Capri / Elba PEDI Spa wurde als erste Einheit entwickelt und muss in einer geeigneten Struktur und auf einem stabilen Boden aufgestellt werden. Alle wasserhaltigen Geräte wiegen ca. 141Kg. Es wird empfohlen, einen Techniker zu konsultieren, bevor Sie das Gerät in einer geeigneten Kabine aufstellen.



ACHTUNG! Capri PEDI Spa hat 4 verstellbaren Füße. Es ist wichtig, dass die 4 Füße reguliert sind, um jede Unvollkommenheit des Bodens auszugleichen.



ACHTUNG! Legen Sie Ihre Hände zum Positionieren in der Kabine oder zum Bewegen Ihres Capri / Elba PEDI Spa unter die hölzerne Beckenabdeckung und nehmen Sie nur den Metallrahmen.



HEBEN SIE DAS CAPRI/ ELBA PEDI SPA NIEMALS AN DER HOLZABDECKUNG.

2.2. Demontage der Holzbeckenabdeckung



ACHTUNG! Capri/Elba PEDI Spa wird mit dem Stuhl geliefert, der aus dem in der folgenden Abbildung gezeigten Wanne ausgebaut ist.



2.3. Demontage der Basis



SCHRITT 1: Entfernen Sie die obere Abdeckplatte



SCHRITT 2: Lösen Sie die 4 Schrauben mit dem passenden Schlüssel, um die hintere Holzabdeckung zu entfernen



SCHRITT 3: Entfernen Sie die hintere Holzabdeckung



SCHRITT 4: Entfernen Sie die linke seitliche Holzabdeckung

2.4. Hydraulische anschlüsse



ACHTUNG! Alle hydraulischen Anschlüsse müssen von einem zugelassenen Installateur gemäß den örtlichen und nationalen Installationsvorschriften ausgeführt werden.



ACHTUNG! Lassen Sie vor dem Anschließen von Warm- und Kaltwasserrohren an das Wasserversorgungssystem das Wasser aus der Wasserversorgung fließen, um sicherzustellen, dass alle Abfälle aus den inneren Rohren austreten.

VERBINDUNGEN:

- Anschlüsse für Warm- und Kaltwasserleitungen müssen mit 1/2" oder ähnlichem ausgeführt werden
- **HEIßES WASSER (ROT)** 1/2" weiblich
- **KALTES WASSER** 1/2" weiblich



WICHTIG: Abflussanschlüsse sind flexible PVC mit einem Durchmesser von 40mm.

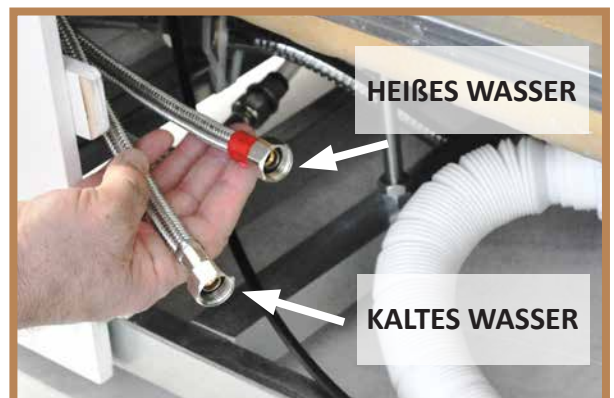

MERKE! Für einen regelmäßigen wasserfluss empfehlen wir den 40mm Bodenablauf so niedrig wie möglich (bodenhöhe). Anschlüsse müssen gemäß den Anforderungen der bestehenden lokalen und nationalen Vorschriften realisiert werden.



Wir empfehlen, widerstandsfähige Fliesen auf dem umgebenden Boden zu verwenden. Zusätzlich zum Capri Pedi Spa Abfluss empfehlen wir, den Boden bei Abfluss von Wasser in Richtung eines zweiten Abflusses zu neigen. **Diese Vorsichtsmaßnahmen gewährleisten sowohl dem Kunden als auch dem Bediener eine sichere Umgebung.**

2.5. Electrical connections

Stecken Sie das Netzkabel in eine geeignete Steckdose, um das Gerät zu bedienen.



ACHTUNG! Wenn die Steckdose und der Stecker des Geräts nicht kompatibel sind, ersetzen Sie die Steckdose durch einen geeigneten Typ, der von qualifiziertem Fachpersonal beschafft wurde. Ziehen Sie den Stecker aus der Steckdose und fassen Sie den Stecker und nicht das Kabel an.

2.6. Sitzmontage



SCHRITT 1: Lösen Sie die Schraube am Stift des Sitzes



SCHRITT 2: Um den Sessel am Qaschbecken zu befestigen, nehmen Sie das Metallteil, das den Arm mit dem Rücken verbindet, und setzen Sie den Stift in das Loch am Metallrahmen des Beckens.



WICHTIG: Vergewissern Sie sich, dass der Messingring am Stift fest sitzt, wenn Sie den Sitz platzieren.



SCHRITT 3: Schrauben Sie um den Sitz zu fixieren.

2.7. Installation der Perimeter Holzabdeckungen



SCHRITT 1: Montieren Sie die linke und die rechte Holzabdeckung wie auf dem linken Bild gezeigt.



SCHRITT 2: Setzen Sie die hintere Holzabdeckung wieder in die entsprechenden Führungen ein und drücken Sie auf die Seiten, um sie zu besfestigen.



SCHRITT 3: Befestigen Sie hintere Holzabdeckung wieder in die entsprechenden Führungen ein und drücken Sie auf die Seiten, um sie zu befestigen.



SCHRITT 4: Schließen Sie die obere Abdeckplatte.

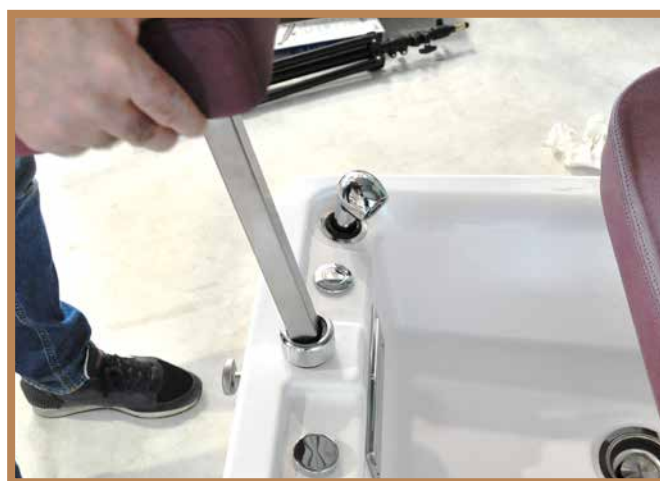

SCHRITT 5: Setzen Sie die Fußstütze wie in der Abbildung unten gezeigt in das entsprechende Loch ein. Zur Einstellung siehe "Arbeitsanweisungen".

3. ARBEITSANWEISUNGEN

3.1. Füllung der Wanne

Vergewissern Sie sich vor dem Befüllen Ihres Capri PEDI SPA mit Wasser, dass die Wanne sauber und sterilisiert ist und dass es sich kein Schmutz in der Wanne befindet, um die Gefahr von Kratzern auf der Acryloberfläche zu vermeiden. Öffnen Sie den Wasserhahn und stellen Sie die Wassertemperatur ein, indem Sie ihn für heißes Wasser rechts und für kaltes Wasser links drehen.



AKTIVIEREN SIE DIE HYDROMASSAGEPUMPE NICHT OHNE WASSER. DER WASSERSTAND MUSS IMMER DEN HYDROMASSAGE-MAGNA-STRAHL ABDECKEN.

3.2. Gebrauch und Wartung der Ausrüstung

AUTOMATISCHE BEFÜLLUNG DES BECKENS UND AKTIVIERUNG DER HYDROMASSAGE (NUR FÜR CAPRI PEDI SPA)

Drücken Sie die Taste **AUTO FILL** um die Wanne automatisch zu füllen (Sensor bis zum eingestellten Füllstand). Wenn der Wasserstand erreicht ist, stoppt der Wasseraustritt und der Luftstrahl (Hydromassage) wird automatisch aktiviert.

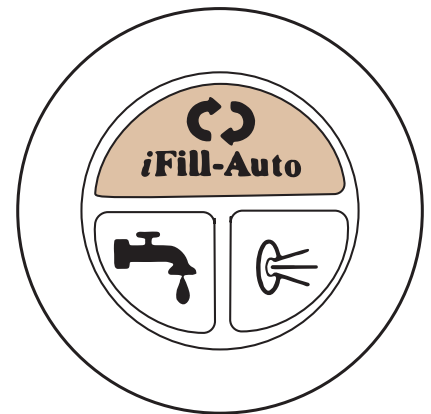

MANUELLE BEFÜLLUNG DER WANNE (NUR FÜR CAPRI PEDI SPA)

Drücken Sie die **TAP** Taste zum manuellen Befüllen. Um den Wasseraustritt zu stoppen, drücken Sie nochmals die gleichen Taste.



DIE WASSERSTAND MUSS IMMER ÜBER DEM WASSERMASSEGESTRAHL LIEGEN.

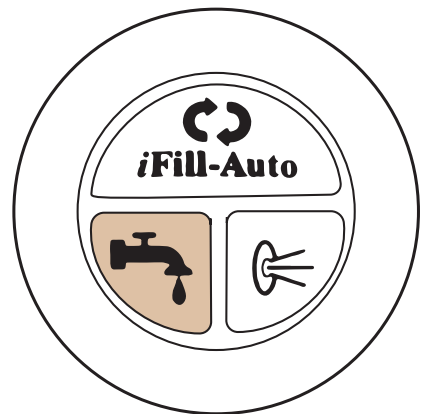

HYDROMASSAGE

Um die Hydromassage zu aktivieren, drücken Sie die Taste mit dem **PUMPE** Symbol, sobald das Wasser den Magna-Wassersand erreicht hat.

HYDROMASSAGE (FÜR ELBA PEDI SPA)

Drücken Sie die ganze Taste, um die Hydromassage im **Elba PEDI SPA** zu aktivieren.

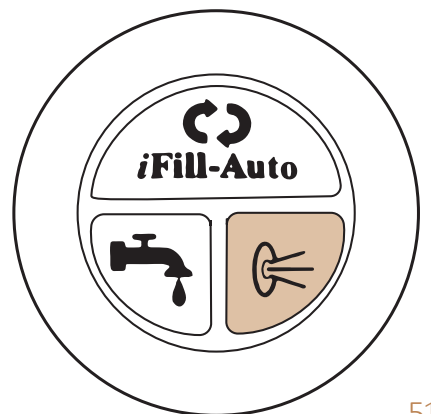



ACHTUNG!

DER WASSERSTAND MUSS IMMER DEN HYDROMASSAGE MAGNA JET ABDECKEN (A).

Tatsächlich besteht nach 30 Sekunden Trockenlauf (B) oder teilweiseem Wasserstand (C) die Gefahr, dass das Laufrad überhitzt und bricht und unbrauchbar wird. Eingriffe an der Maschine, die auf einen falschen Gebrauch dieser Anleitung zurückzuführen sind, fallen nicht unter die Garantie.



A. Der Wasserstand MUSS IMMER DEN HYDROMASSAGE MAGNA JET ABDECKEN



B. Zustand des Laufrads, das für das FEHLEN VON WASSER zerstört wurde



C. Zustand des Laufrades für TEILBEFÜLLUNG ruiniert

3.3. Steuergerät-RESET-Prozedur (NUR für CAPRI PEDI SPA)

Falls ihr Capri Pedi Spa Betriebsprobleme hat, insbesondere beim automatischen Befüllen des Systems, empfehlen wir, mit dem folgenden Resetprozedur fortzufahren.

1) Schalten Sie die Maschine für einige Sekunden aus, warten Sie einige Sekunden und schließen Sie das Capri Pedi Spa wieder an die Stromversorgung an. Halten Sie die **iFill-Auto Taste gedrückt**, bis ein längerer Ton zu hören ist. Sobald der Druck nachlässt, beginnen die LEDs zu blinken.

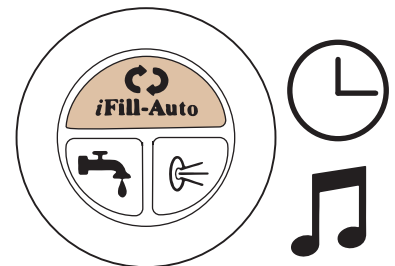

2) Nachdem Sie den Ton gehört haben, drücken Sie die **Hydromassage Taste**.

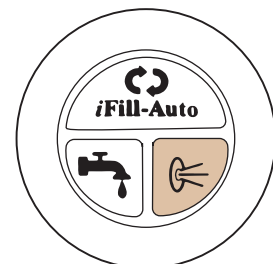

3.4. Hydromassage Magna Jet reinigung

1. Nehmen Sie es aus der Wanne
2. Drehen Sie die 2 Plastikabdeckungen zum Öffnen
3. Trennen Sie die 2 Kunststoffteile
4. Entfernen Sie das interne Laufrad
5. Putze es:
 - 5.1 Legen Sie die Kunststoffabdeckungen und das Laufrad in ein Bad mit 20 cl SANIGUEST Reinigungsmittel
 - 5.2 Mit klarem Wasser abdecken
 - 5.3 2 Stunden einweichen lassen
 - 5.4 Mit einem weichen, sauberen Tuch trocknen, keinen kratzenden Schwamm verwenden
6. Teile wieder zusammenbauen
7. Stellen Sie den Jet auf die Wanne



3.5. Positionierung der Hydromassage Magna Jet

Der Magna Jet muss mit den Löchern horizontal positioniert werden. Dank des Magneten wird das Bauteil an der Wanne befestigt.



3.6. Benutzung der Handbrause

Um die Handbrause zu benutzen, ziehen Sie den Umsteller am Wasserhahn und drehen Sie ihn, um ihn zu verriegeln. Auf diese Weise fließt Wasser aus der Handbrause. Setzen Sie die Handbrause in das entsprechende Loch links in der Wanne, wenn Sie sie nicht benutzen.



3.7. Ablassen

Links/Rechts schieben, um den Ablauf zu schließen oder zu öffnen.



3.8. Fußstützeverstellung

Um die Höhe der Fußstütze einzustellen, schrauben Sie die vordere Abdeckung gegen den Uhrzeigersinn ab und bewegen Sie das Polsterteil mit der anderen Hand nach oben oder unten. Im Uhrzeigersinn drehen, um die Position zu fixieren.



Zum Vor- oder Zurückschieben des Polsterkissens den schwarzen Knopf lösen und festschrauben.

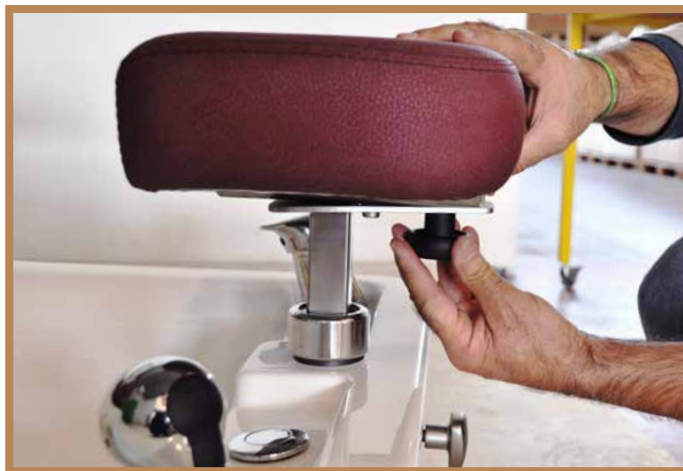

3.9. Sitzverstellung und Neigung

Der Sitz ist elektrisch vorwärts oder rückwärts vertellbar. Zum Einstellen des Sitzes drücken Sie die Knöpfe an der Vorderseite der Wanne.



Ziehen Sie den Hebel auf der rechten Seite des Stuhls und bewegen Sie die Rückenlehne des Sitzes, um die Neigung des Sitzes anzupassen. Lassen Sie den Hebel los, um ihn zu fixieren.

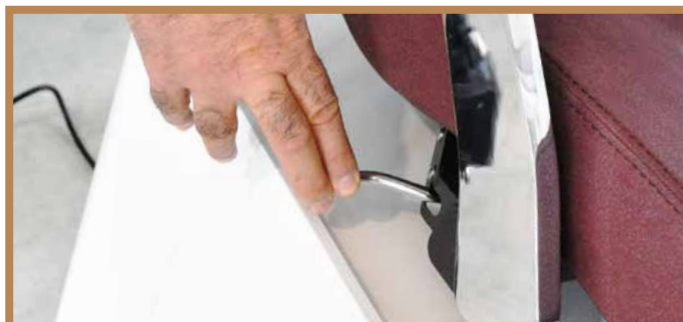

3.10. Sitzdrehverstellung

Der Stuhl kann um 180° von einer Seite zur anderen gedreht werden um den Zugang zum Kunden zu erleichtern. Bewegen Sie den Stuhl nach links oder rechts.



ACHTUNG! Der Kunde darf den Stuhl nur in "gedrehter" Position betreten oder verlassen.

3.11. Positionierung von Maniküreschalen

Platzieren Sie den Metallrahmen auf jeder Armlehne. Stellen Sie die Schalen auf den Rahmen.



4. INSTALLATIONSSCHEMA

4.1 Installation an Strom- / Wasserleitung

KAPAZITÄT DES ELEKTRISCHES SYSTEMS:

Spannung 220V 2 phasen + erdung

KAPAZITÄT DES WASSER SYSTEMS:

8 Liter / Minute

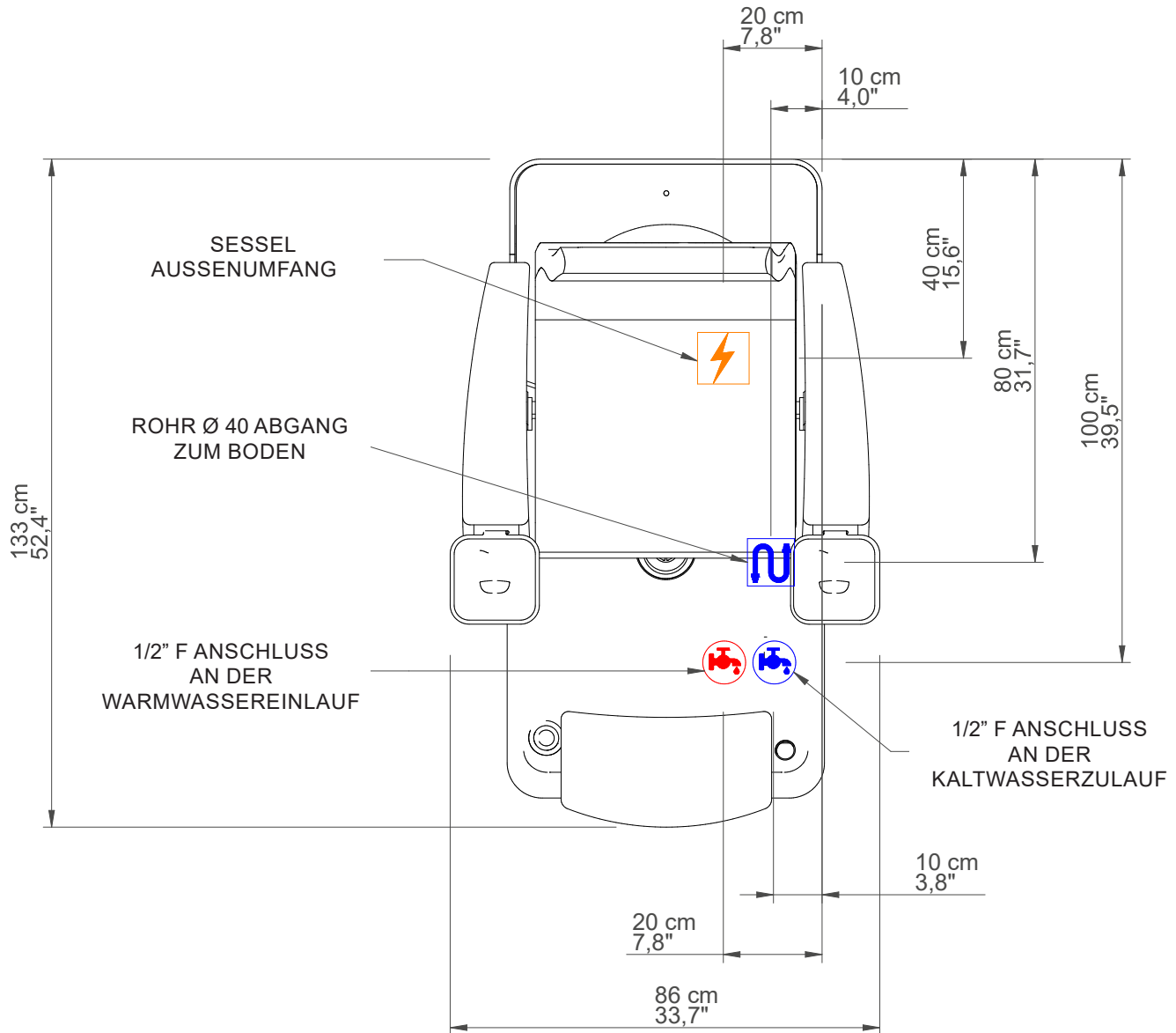

ACHTUNG! Für die Wandentwässerung müssen Sie die Entwässerungspumpe (Optional) hinzufügen



ACHTUNG!

Das Wandablauf-SET wird im Gehäuse des Sessels montiert und von außen über einen **LIGURIA-Typ Gummischlauch Ø 22mm mit einer Länge von 3m** angeschlossen

5. REINIGUNG

REINIUNG VON GLASFASERWANNE



Es ist verboten, die folgenden Produkte zu verwenden, die die Kunststoffabdeckung ernsthaft beschädigen, Risse hervorrufen und anschließend brechen können:

- Entfettungsmittel auf Lösungsmittelbasis: z.B. ACETON, DENATURIERTES ETHYLALKOHOL, TRICHLORETHYLEN, KRAFTSTOFF, TURPENTIN
- Verwässerungssäuren (HYDROCLORIDIC ACID, NITRIC ACID) oder Produkte, die verwässerten Säuren enthalten
- Verwässerte Basen (CAUSTIC SODA, SODIUM HYPOCHLORITE, AMMONIA, BLEACH) oder Produkte mit schwachen Basen
- Fluorierte Kohlenwasserstoffe (z.B. LECKE AUS KÄLTEMITTELGAS)
- Öle in Lebensmittelqualität (z.B. OLIVENÖL, SAMENÖL)
- Mineralöle schmieren



Zur REINIGUNG empfehlen wir:

- Seifenwasser (Neutrale Seife)
- Weicher Schwamm

Immer mit klarem Wasser abspülen und mit einem weichen, nicht scheuernden Tuch trocknen.

STUHLREINIGUNG

Wir empfehlen, den Stuhl mit einem Handtuch oder Einweg-Laken zu bedecken, bevor der Kunde sitzt.



Achten Sie besonders auf die Jeans, die Flecken auf dem Bezug hinterlassen können, ohne dass diese entfernt werden können.



Reinigen Sie den Stuhl vor jedem Gebrauch und achten Sie dabei besonders darauf, alle physiologischen Flüssigkeitsspuren des vorherigen Patienten zu entfernen.



Verwenden Sie zum Reinigen des Stuhls ein Tuch und lauwarmes Wasser (ggf. Verdünntes neutrals Reinigungsmittel). Wenn nötig ein nicht aggressives Desinfektionsmittel, dann mit einem sauberen Färbetuch abwischen.

Verwenden Sie keine Produkte wie Alkohol, Aceton, Bleichmittel, Farbberdüner oder Benzin.

INSTANDHALTUNG

1) **NACH** jeder einzelnen Behandlung/Klient, bevor eine neue Behandlung begonnen.

Wird die Wanne leeren, die Wanne mit Kontakt-Desinfektionsmittel SANIGUEST besprühen und mit einem weichen Schwamm oder Tuch reinigen. Spülen Sie die Wanne mit der Handbrause.

2) **REGELMÄßIG** (einmal pro Woche oder alle 2 Wochen, je nach Wasserhärte):

Besprühen Sie die Wanne mit GO KAL Entkalkungsmittel und vermeiden Sie dabei den Kontakt mit Augen und Haut. Reinigen Sie es mit einem weichen Schwamm oder einem Tuch. Lassen Sie das Wasser einige Sekunden lang reichlich aus den Düsen fließen, um starke Ablagerungen zu entfernen. Mit Handbrause abspülen.



WICHTIG! Verwenden Sie keine Creme- oder Puderreiniger, Desinfektionsmittel oder kratzende Schwämme oder Tücher. **VERWENDEN SIE KEINE BLEICHLÖSUNG ODER ANDERE ÄTZENDE MITTEL, UM DEN STUL ZU REINIGEN.**

N.B. Wenn Sie unser Desinfektionsmittel SANIGUEST oder GOKAL bestellen möchten, senden Sie uns bitte eine E-Mail an orders@lemigroup.it

Die strikte Beachtung dieser einfachen Reinigungs- und Pflegehinweise hält Ihre Wanne lange Zeit sauber, weiß und hell.

AUSSENMASS

Maße in Zoll und CM

CAPRI PEDI SPA

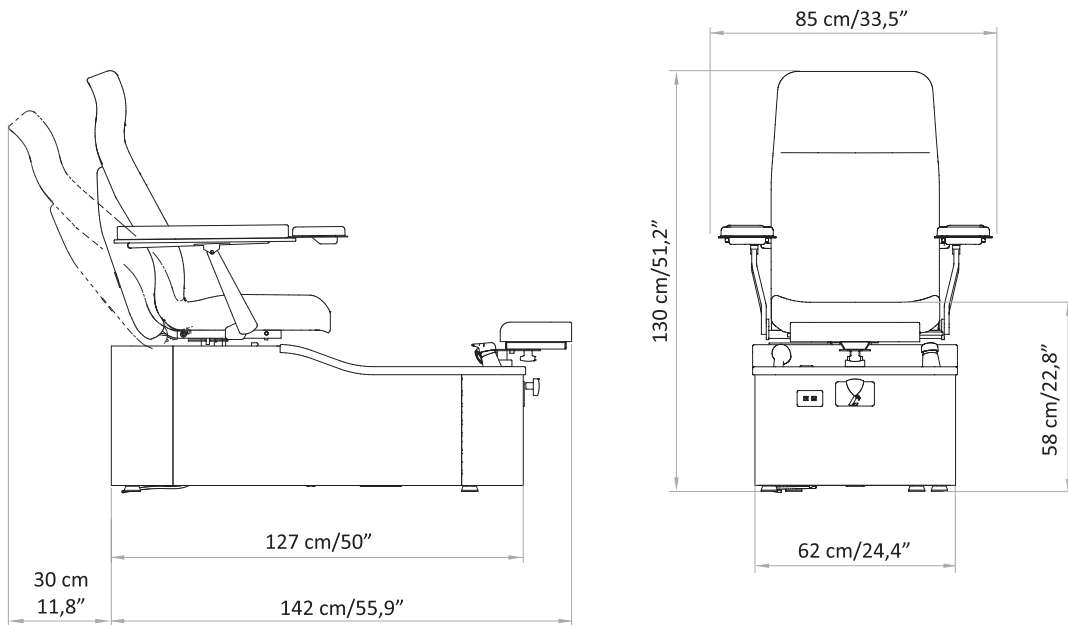

ELBA PEDI SPA

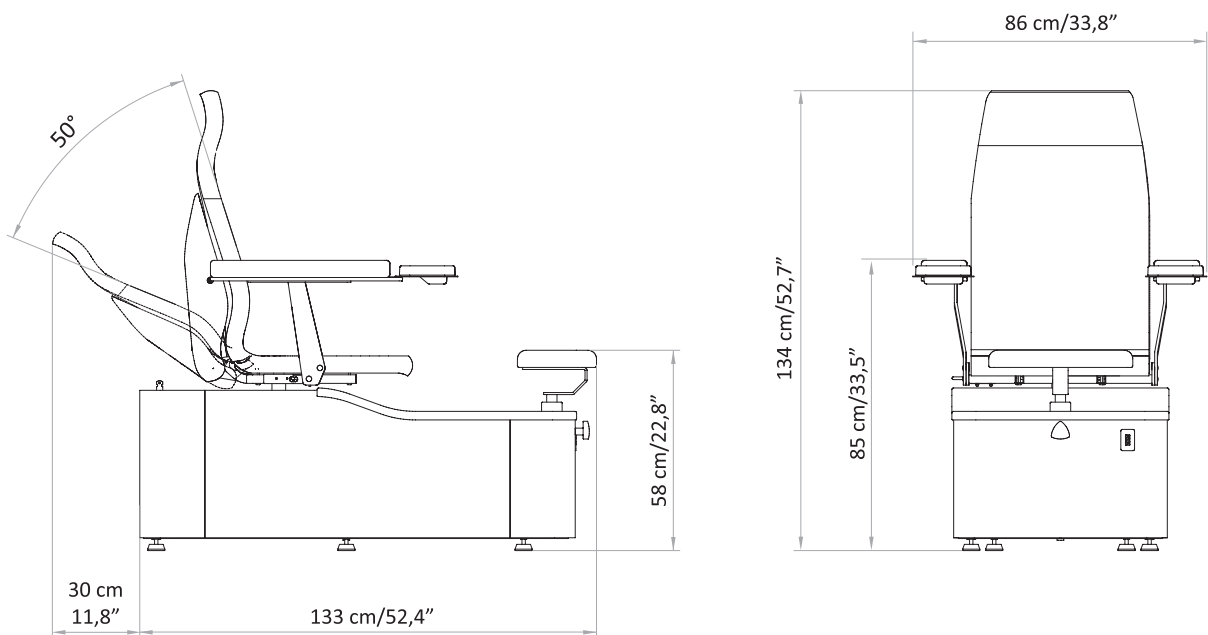

This publication or parts thereof may not be reproduced, stored in a storage machine, transmitted, transcribed, or translated into any language, usual or computer, in any form or by any means, electronic, mechanical, magnetic, optical, chemical, manual or otherwise, without the express written permission of the manufacturer, Brusaferrri & C. The manufacturer shall provide warranty with respect to the contents of this publications, with the express prohibition of the use of the same publication for any other purpose whatsoever, commercial, practical, technical-scientific, unrelated to the functioning of the equipment to which it relates for which this issue has been written. The warranty on the accuracy of the information contained herein is provided on condition that they are strictly observed by the user of the device, all the prescriptions contained in this documentation. Moreover Brusaferrri & C. reserved the right to revise this publication and to make changes in the content without obligation to notify any person or organization. These revised publications are available on request by Brusaferrri & C.

©2023 Brusaferrri & C. – All rights reserved.

Designed and manufactured by:

Lemi[®]
ITALIAN WELLNESS EQUIPMENT

Via Mara Maretti Soldi, 13
26011 Casalbuttano (CREMONA) ITALY
Phone +39-0374-363069 Fax +39-0374-363071
info@lemigroup.it service@lemigroup.it
www.lemigroup.it