

Lemi[®]

ITALIAN WELLNESS EQUIPMENT



HEMODIALYSIS
BLOOD SAMPLING
EMODIALISI
PRELEVI



* M: Nefos 6 Standard version / Versione standard



* M: Nefos 8019 Hemodialysis - blood sampling version
Versione emodialisi - prelievi



* M: Nefos 5946 Gynaecology version
Versione ginecologia

COD. 1132

Lemi Med is equipped with high-performance and silent electronics and a practical standard foot pedal control. Bi-Zak mattress with wide customization.

IDEAL FOR: diagnostics, check-up, hemodialysis and blood sampling, gynecological examinations, dermatology and aesthetic surgery.

Lemi Med è dotata di elettronica altamente performante e silenziosa e di una pratica pedaliera standard. Materasso Bi-Zak con ampia possibilità di personalizzazione.

IDEALE PER: diagnostica, check-up, emodialisi e prelievo di sangue, esami ginecologici, dermatologia e chirurgia estetica.

* The images are for illustrative purposes only and may not reflect the actual image of the finishing.

* Le immagini hanno valore puramente illustrativo e possono non rispecchiare l'immagine reale della finitura.

Focus on

Standard foot pedal control with 1 MEMORY function **NEW**

- AUT function: automatic return to the original position (chair)
- SYNCHRO function: synchronized backrest/legrest movement (ONLY by handset control)
- Fire retardant class 1IM, "Azo" free, antibacterial, antifungal covering
- Entirely enclosed ABS casing
- Fully customizable

▪ Standard version includes: 4 electric motors (height, back, leg, trendelenburg adjustment), foot pedal control and anatomic Bi-Zak mattress (adjustable headrest and footrest), 2 pairs of guides (back and seat) and a roll-holder

Pedaliera standard con 1 funzione MEMORIE **NEW**

- Funzione AUT: ritorno automatico alla posizione base (poltrona)
- Funzione SYNCHRO: movimento schiena/gambe sincronizzato (SOLO con pulsantiera)
- Rivestimento ignifugo classe 1IM, "Azo" free, antibatterico, antimicotico
- Carter in ABS completamente chiuso
- Totalmente personalizzabile

▪ La versione standard include: 4 motori elettrici (regolazione altezza, schienale, gamba, trendelenburg), pedaliera e materasso anatomico Bi-Zak (testa e piedi regolabili), 2 coppie di guide (schiena e seduta) e portarotolo

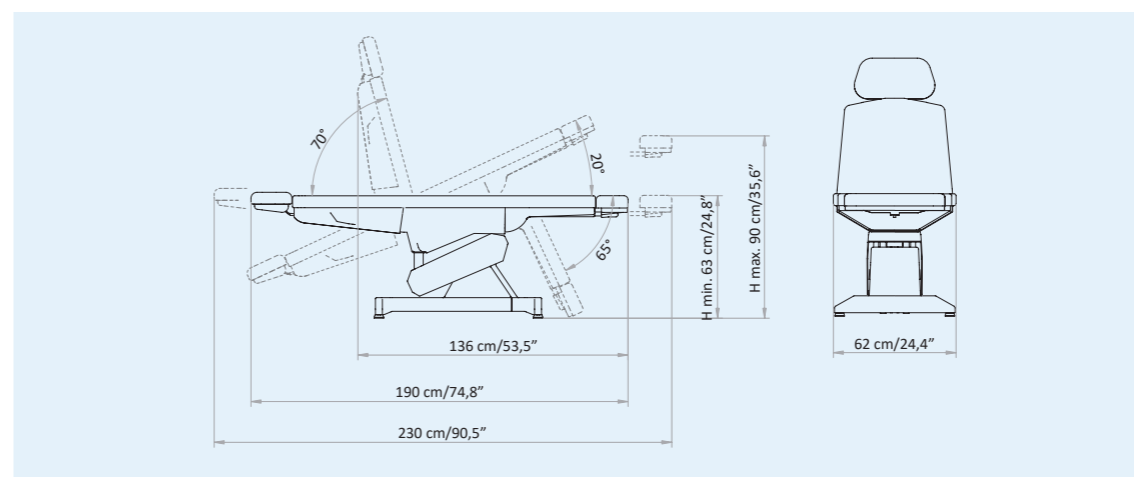

Packaging details

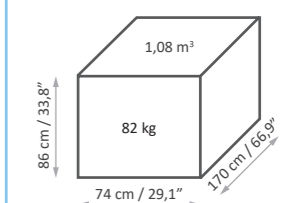

MAXIMUM CAPACITY
PORTATA MASSIMA
200 kg

HEMODIALYSIS BLOOD SAMPLING EMODIALISI PRELIEVI

LEMI MED

GYNAECOLOGY GINECOLOGIA

LEMI MED



STANDARD CONTROL

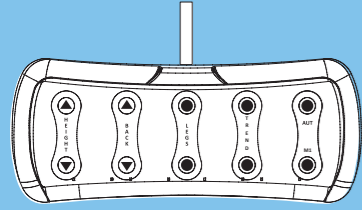

4 ELECTRIC MOTORS



M1 - MEMORY FUNCTION



AUT FUNCTION

COMANDO STANDARD

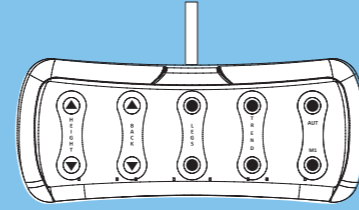

4 MOTORI ELETTRICI



M1 - FUNZIONE MEMORIE



FUNZIONE AUT



Removable Zak headrest
Testa Zak estraibile

63-90 cm
(24,8"-35,6")

Electric height
Altezza elettrica



Electric backrest
Schiena elettrica



70°

20°

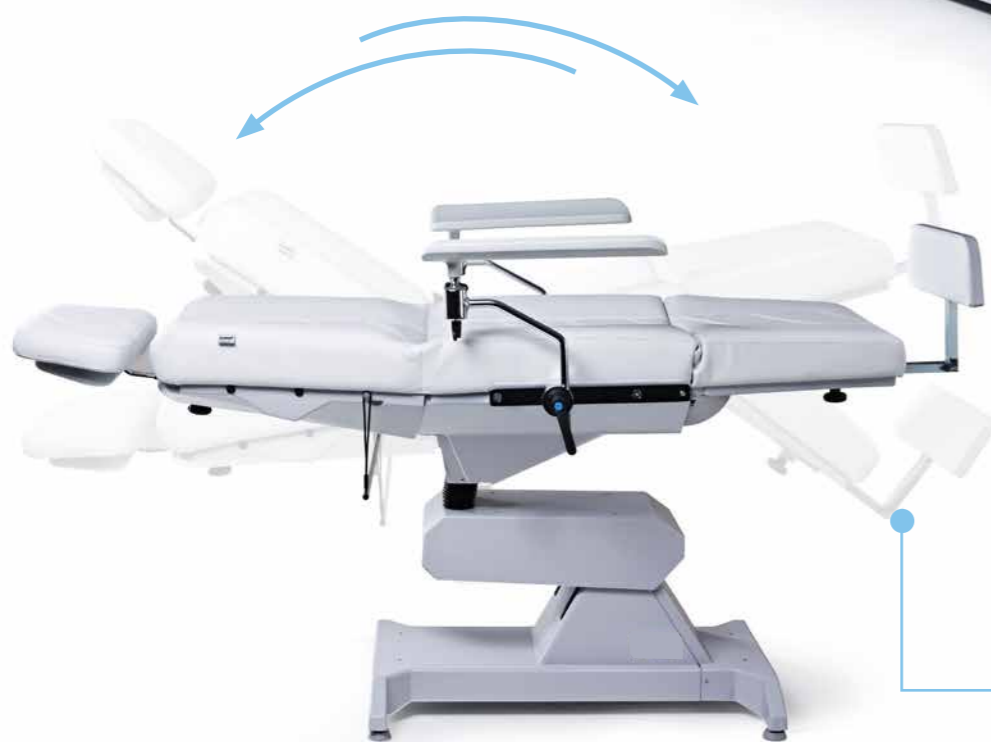

Electric Trendelenburg
Trendelenburg elettrico

Electric legrest
Gamba elettrica

65°



Hemodialysis / blood sampling version
Versione emodialisi / prelievi

Removable Hemo foot support
Supporto piede Hemo estraibile

MATTRESS CUSTOMIZATION PERSONALIZZAZIONE MATERASSO



NEFOS - COLOR CHART

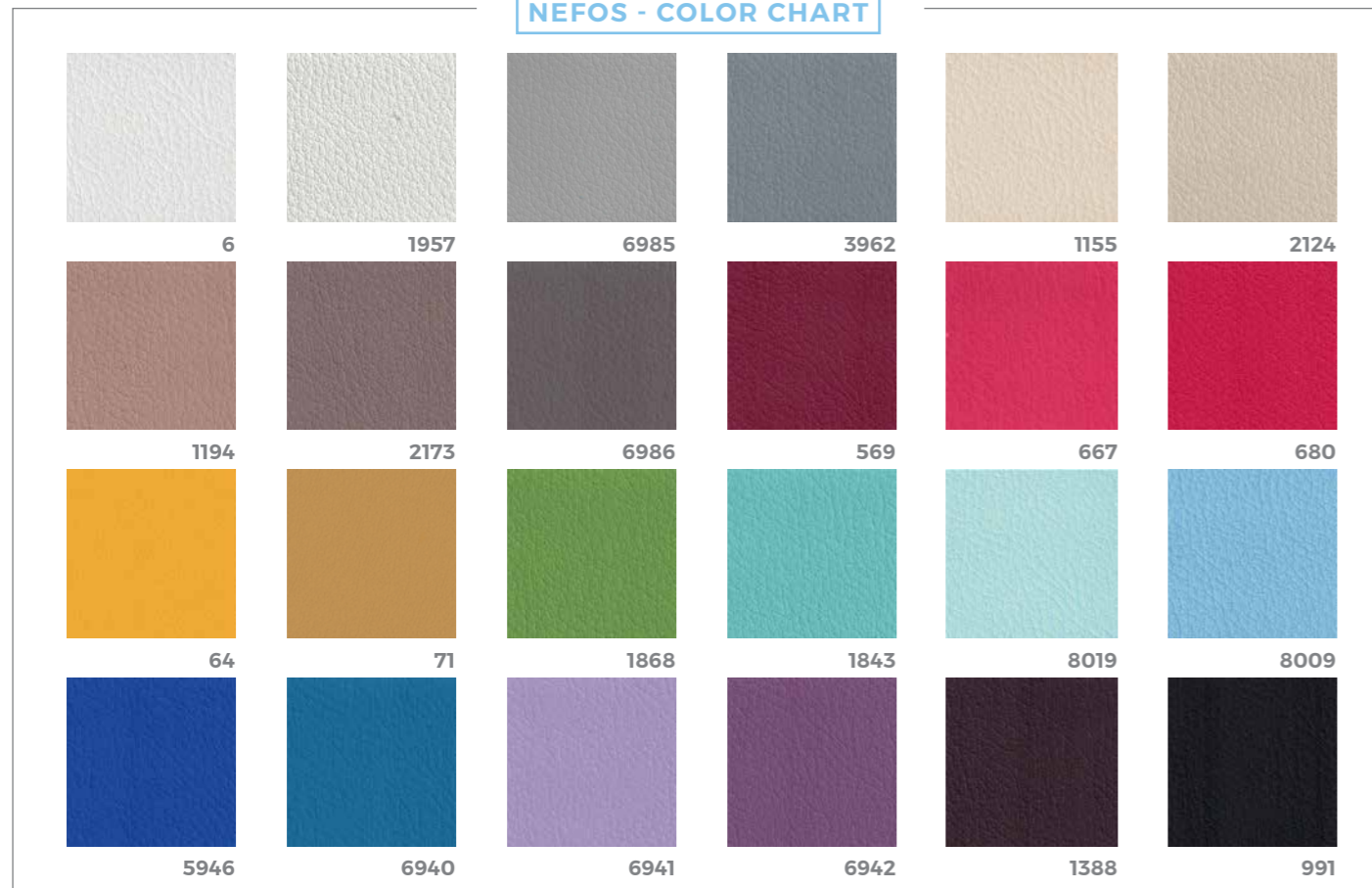

The innovative Nefos materials - which are exclusive for LEMI products - and their special finishing touch guarantee easy-cleaning and hygiene. Their extraordinary structural qualities will persist through the years. An incredibly elastic texture enhances the memory foam mattress softness and quality at its best.

Gli innovativi materiali Nefos - che sono un'esclusiva dei prodotti LEMI - ed il loro speciale tocco di finitura garantiscono una facile pulizia e igiene. Le loro straordinarie qualità strutturali permangono nel corso degli anni. Una texture incredibilmente elastica migliora al massimo la morbidezza e la qualità del materasso in Memory Foam.

The images are for illustrative purposes only and may not reflect the actual finish of the product, particularly when viewed through a screen. Therefore, the **SELECTION OF MATTRESS FABRICS** must take place **AFTER CONSULTING** the **PHYSICAL SAMPLES** of the **COLOR CHARTS**.

ANTIMICROBIAL TECHNOLOGY TECNOLOGIA ANTIMICROBICA

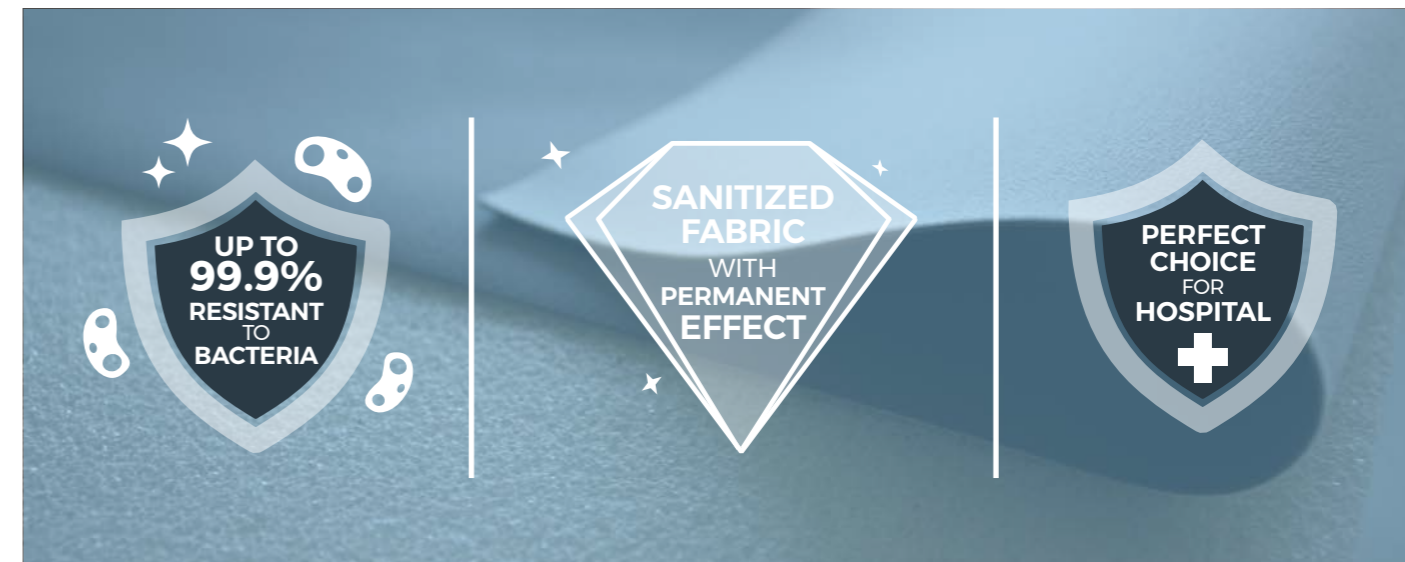

WHAT DOES IT MEAN?

The Nefos vinyl leather fabric is made through production processes involving an antimicrobial additive technology. Studies show that fabrics treated with this technology are up to 99.9% resistant to harmful bacteria.

The exceptional result that derives from it is a sanitized fabric with a permanent effect, whose matrix guarantees safety from any contamination thanks to the antibacterial, antifungal and anti-mold effect, which protects the coating from fungal attacks that can cause damage or bad smells, for the entire product's life cycle. The antimicrobial additive technology protects the fibers without changing their characteristics, thus preserving their freshness over time.

A high level of hygiene is essential, that's why this kind of technology was chosen by LEMI for all its bed and chair lines. The peculiarity of these coatings has allowed LEMI to give further value to its products, since thanks to this technology, the cleaning phase of Nefos vinyl leather fabric does not require the use of sanitizing products but requires the use of a soft cloth moistened and soapy, to be rinsed simply with clean water.

CHE COSA SIGNIFICA?

La linea di rivestimenti in vinilpelle Nefos è realizzata attraverso processi produttivi che coinvolgono una tecnologia additivante antimicrobica. Studi dimostrano che i tessuti trattati con questa tecnologia sono resistenti fino al 99,9% ai batteri nocivi.

Il risultato eccezionale che ne deriva è un tessuto igienizzato ad effetto permanente, la cui matrice garantisce sicurezza da eventuali contaminazioni grazie all'effetto antibatterico, antifungino e antimuffa, il quale protegge il rivestimento da attacchi micotici che possono essere causa di danni o di cattivi odori, per l'intera durata del ciclo di vita del prodotto. La tecnologia additivante antimicrobica protegge le fibre senza modificarne le caratteristiche, conservandone così la freschezza nel tempo.

Un alto livello di igiene è fondamentale, ecco perché questo tipo di tecnologia è stata scelta da LEMI per tutte le sue linee di poltrone e lettini. La peculiarità di questi rivestimenti ha permesso a LEMI di dare un ulteriore pregio ai propri prodotti, poiché proprio grazie a questa tecnologia, la fase di pulizia dei tessuti vinilpelle Nefos non necessita dell'utilizzo di prodotti igienizzanti ma prevede l'uso di un panno morbido inumidito e insaponato, da sciacquare semplicemente con acqua pulita.

Le immagini hanno valore puramente illustrativo e possono non rispecchiare la finitura reale del prodotto, in particolare se visualizzate attraverso uno schermo. Pertanto la **SELEZIONE** dei **RIVESTIMENTI** dei **MATERASSI** deve avvenire **PREVIA CONSULTAZIONE** della **CAMPIONATURA FISICA** delle **CARTELLE COLORI**.

BASE CUSTOMIZATION PERSONALIZZAZIONE BASE

ABS PLASTIC FINISHES



White
Bianco



Grey
Grigio



Black
Nero

We provide a thermoformed ABS base, completely closed to prevent any infiltration of powders or liquids. The result is a very strong material that is scratch resistant and easy to clean.

Forniamo una base in ABS termoformato, completamente chiuso per evitare qualsiasi infiltrazione di polveri o liquidi. Il risultato è un materiale molto robusto, resistente ai graffi e facile da pulire.

The images are for illustrative purposes only and may not reflect the actual finish of the product, particularly when viewed through a screen. Therefore, the **SELECTION OF THE FINISHES** of the **BASES** and **MATTRESS FABRICS** must take place **AFTER CONSULTING** the **LUXURY BOX PHYSICAL SAMPLES** and the **COLOR CHARTS**.

Le immagini hanno valore puramente illustrativo e possono non rispecchiare la finitura reale del prodotto, in particolare se visualizzate attraverso uno schermo. Pertanto la **SELEZIONE DELLE FINITURE** delle **BASI** e dei **RIVESTIMENTI** dei **MATERASSI** deve avvenire **PREVIA CONSULTAZIONE** della **CAMPIONATURA FISICA** della **LUXURY BOX** e delle **CARTELLE COLORI**.

ACCESSORIES UPON REQUEST ACCESSORI SU RICHIESTA

All chairs have a standard setting customizable upon request.

Tutte le poltrone hanno una configurazione standard personalizzabile su richiesta.



Small Zak headrest
Testa Zak piccola



Strip headrest
Testa strip



Anto headrest for hair transplant
Testa Anto per trapianto capelli



Plastic leg protection
Proteggi gambe in plastica



Handset control with memory function
Pulsantiera con funzione memorie



Wireless foot pedal control with memory function
(NO foot pedal with cable NO remote control)
Pedaliera wireless con funzione memorie
(NON compatibile con il pedale a filo e con la pulsantiera)



Fixed clamp
Morsetto fisso



Rotating clamp
Morsetto girevole



Blood sample taking armrest couple
(fixed with fix clamp and guides on the seat)
Coppia braccioli da prelievo con snodo
(da fissare con morsetto fisso e guide seduta)



Medical armrest couple
(to be fixed with rotating clamp and guides on the back)
Coppia braccioli medicali
(da fissare con morsetti girevoli e guide schiena)



Wheels with brake
Ruote con freno



Curtain holder
(fixed with rotating clamp and guides on the seat)
Reggitelo
(da fissare con morsetto girevole e guide schiena)



I.V. Rod
(fixed with rotating clamp and guides on the back)
Asta portaflebo
(da fissare con morsetto girevole e guide schiena)



Heel support couple
(fixed with fix clamp and guides on the seat)
Coppia reggitallone
(da fissare con morsetti fissi e guide sulla seduta)



Thigh supports couple
(fixed with fix clamp and guides on the seat)
Coppia reggicosce con snodo
(da fissare con morsetti fissi e guide seduta)



Inox tray with support
(fixed with fix clamp and guides on the seat)
Vassoio inox completo di telaio
(da fissare con morsetto fisso e guide seduta)



Hemo foot headrest
Supporto piede Hemo



UK cable
Cavo UK



USA cable
Cavo USA



Customization with logo
Personalizzazione con logo

LEMI MATTRESSES

The **MATTRESSES** of the **LEMI MEDICAL** line are made with the best quality materials to ensure maximum comfort for both the patient and the doctor.

Each mattress is **HANDCRAFTED**, therefore the **ACTUAL MEASUREMENTS** MAY VARY from those indicated in the catalogue by approximately ± 1 cm (also based on the selected configuration).

MATERASSI LEMI

I **MATERASSI** della linea **MEDICALE LEMI** sono realizzati con materiali della migliore qualità per garantire il massimo comfort sia per il paziente che per il medico.

Ogni materasso è realizzato **A MANO**, pertanto le **MISURE REALI** POTREBBERO VARIARE rispetto a quelle indicate nel catalogo di circa ± 1 cm (anche in base alla configurazione selezionata).



LEMI MED - HEMO

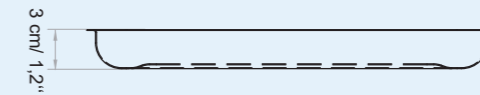
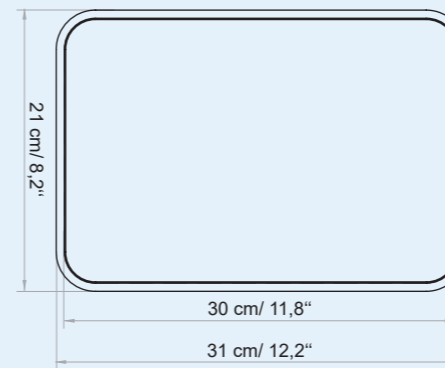
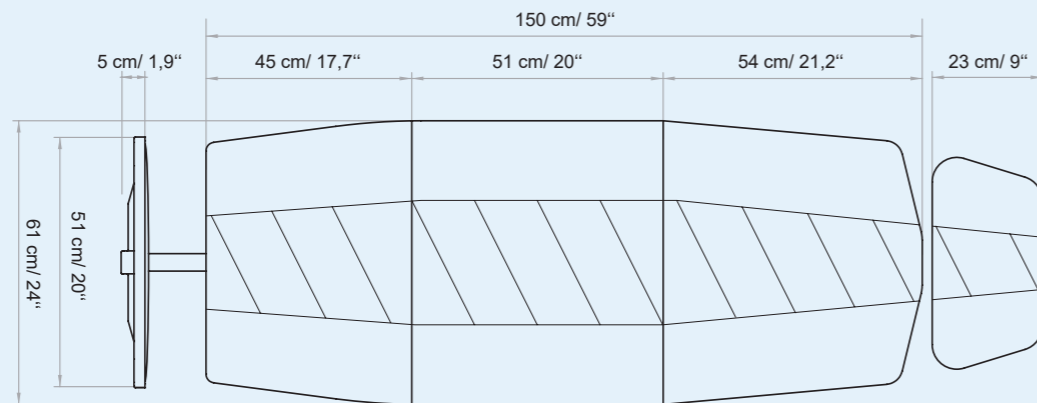

INOX TRAY
VASSOIO INOX



LEMI MED - GYNO

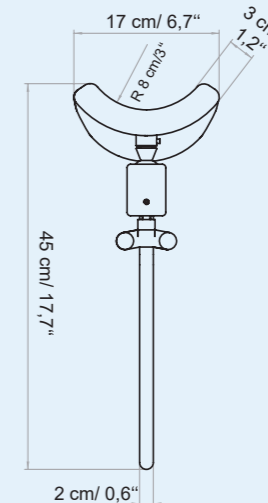
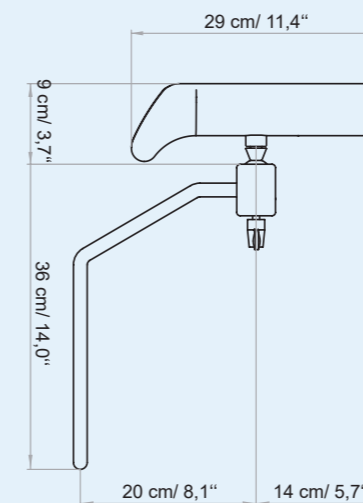
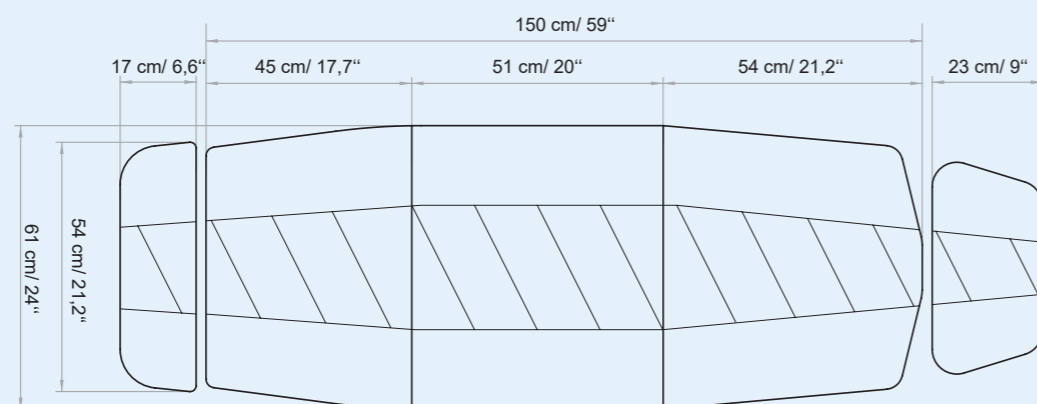

THIGH SUPPORT



TECHNICAL REQUIREMENTS

CARATTERISTICHE TECNICHE

ABSORPTION ASSORBIMENTO	VOLTAGE VOLTAGGIO	POWER POTENZA	FREQUENCY FREQUENZA	PROTECTION RATING GRADO DI PROTEZIONE	ELECTRIC SYSTEM CONFORMS TO CEI NORMS IMPIANTO ELETTRICO A NORME CEI	CONTROL BOX CENTRALINA
4 Amax (1,7 A)	100 Vac (240Vac)	250W	50/60 Hz	IP 54	60601-1	CLASS II

TECHNICAL SPECIFICATION / SPECIFICHE TECNICHE

MINIMUM HEIGHT: 63 CM / 24,8"
 MAXIMUM HEIGHT: 90 CM / 35,6"
 ANGOLO INCLINAZIONE TRENDELENBURG: 20°
 ANGLE OF INCLINATION BACK REST: 70°
 ANGLE OF INCLINATION LEG: 65°
 MATTRESS LENGTH: 190 CM / 74,8"
 MATTRESS WIDTH: 62 CM / 24,4"
 LATEX-FREE, NON-TOXIC AND NON-CARCINOGENIC MATERIALS
 FIRE-RESISTANT UPHOLSTERY: UNI 9175 CLASS I M

ALTEZZA MINIMA: 63 CM
 ALTEZZA MASSIMA: 90 CM
 ANGOLO INCLINAZIONE TRENDELENBURG: 20°
 ANGOLO INCLINAZIONE SCHIENA: 70°
 ANGOLO INCLINAZIONE GAMBE: 65°
 LUNGHEZZA MATERASSO: 190 CM
 LARGHEZZA MATERASSO: 62 CM
 MATERIALI PRIVI DI LATTICE, ATOSSICI E NON CANCEROGENI
 RIVESTIMENTO IGNIFUGO: UNI 9175 CLASS I M

WARRANTY / GARANZIA

STRUCTURE: 10 YEARS | STRUTTURA: 10 ANNI
 MOTORS AND CONTROL: 2 YEARS | MOTORI E CONTROLLI: 2 ANNI
 CUSHION: 5 YEARS | MATERASSO: 5 ANNI

REGULATIONS

All Equipment is **CE** marked

Electrical equipment and beds

Directive 2006/42/CE (Machinery Directive) and national regulations
 Directive 2014/30/UE (Electromagnetic Compatibility Directive) and national regulations.

Hydraulic equipment and beds

Directive 2006/42/CE (Machinery Directive) and national regulations

Images

The images are for illustrative purposes only and may not reflect the actual image of the product.

NORME

Tutte le attrezzature sono a marchio **CE**

Attrezzature e lettini elettrici

Direttiva 2006/42/CE (Direttiva Macchine) e disposizioni nazionali di attuazione
 Direttiva 2014/30/UE (Direttiva Compatibilità elettromagnetica) e disposizioni nazionali di attuazione.

Attrezzature e lettini idraulici

Direttiva 2006/42/CE (Direttiva Macchine) e disposizioni nazionali di attuazione

Immagini

Le immagini hanno valore puramente illustrativo e possono non rispecchiare l'immagine reale del prodotto.

Lemi[®]
 ITALIAN WELLNESS EQUIPMENT

Brusaferrì & C srl
 Via Mara Maretti Soldi, 13
 26011 Casalbuttano (CREMONA) ITALY
 Phone +39-0374-363069 Fax +39-0374-363071
 info@lemigroup.it service@lemigroup.it

www.lemimd.com